

ZEXEL - TEST VALUES
Injection pumps

BOSCH No.	:	9 400 610 152	1/4
ZEXEL No.	:	101603-6470	
Date	:	30.05.1991	[0]
Company	:	MITSUBISHI	
Engine	:	6D14CT / MEO70091	

IP-Type number : 101060-9720 / PES6A
Governor type number : 105410-8040 / EP/RSV

TEST PREREQUISITES

Test oil : ISO-4113
Test oil inlet temperature °C : 40.00...45.00
Inlet pressure bar : 1.6
Test nozzle holder combination : 1 688 901 013
Opening pressure bar : 175
Test pressure line
Inner x Outer Dia - Length mm : 2.00 x 6.00 x 600

PORT CLOSING

Prestroke mm : 3.3 ± 0.05
Rod position mm : -
Port closing mark Cyl. No. : -
Cam sequence : 1-5-3-6-2-4

Port closing mark Cyl. No. : -
Port closing difference °NW : 0-60-120-180-240-300

Tolerance +- °C: 0.50 (0.75)

A1

ZEXEL - Test values
Injection pumps



Injection Quantity :

Adjusting Point	Rack Position (mm)	Pump Speed (r.p.m)	Injection Q'ty (cc/1000 str.)	Difference (%)	Fixed	Remarks
A	10.0	700	79.3 - 81.3	± 2.5	Rack	Basic
H	approx. 7.6	375	8.2 - 11.2	± 15.0	Rack	
A	10.0	700	79.3 - 81.3	-	Lever	Basic

Timing Advance Specification : EP/SBZ
105624-5180

Pump Speed (r.p.m)	600	900					
Advance Angle (deg.)	Below 0.5	1.5-2.5					



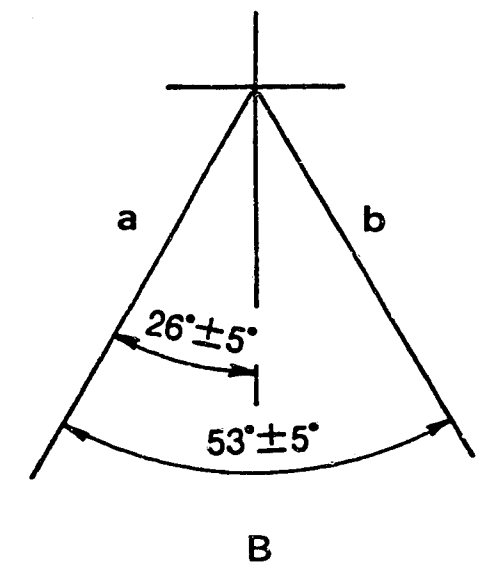
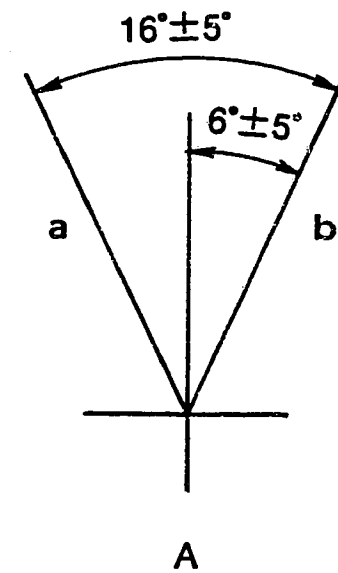
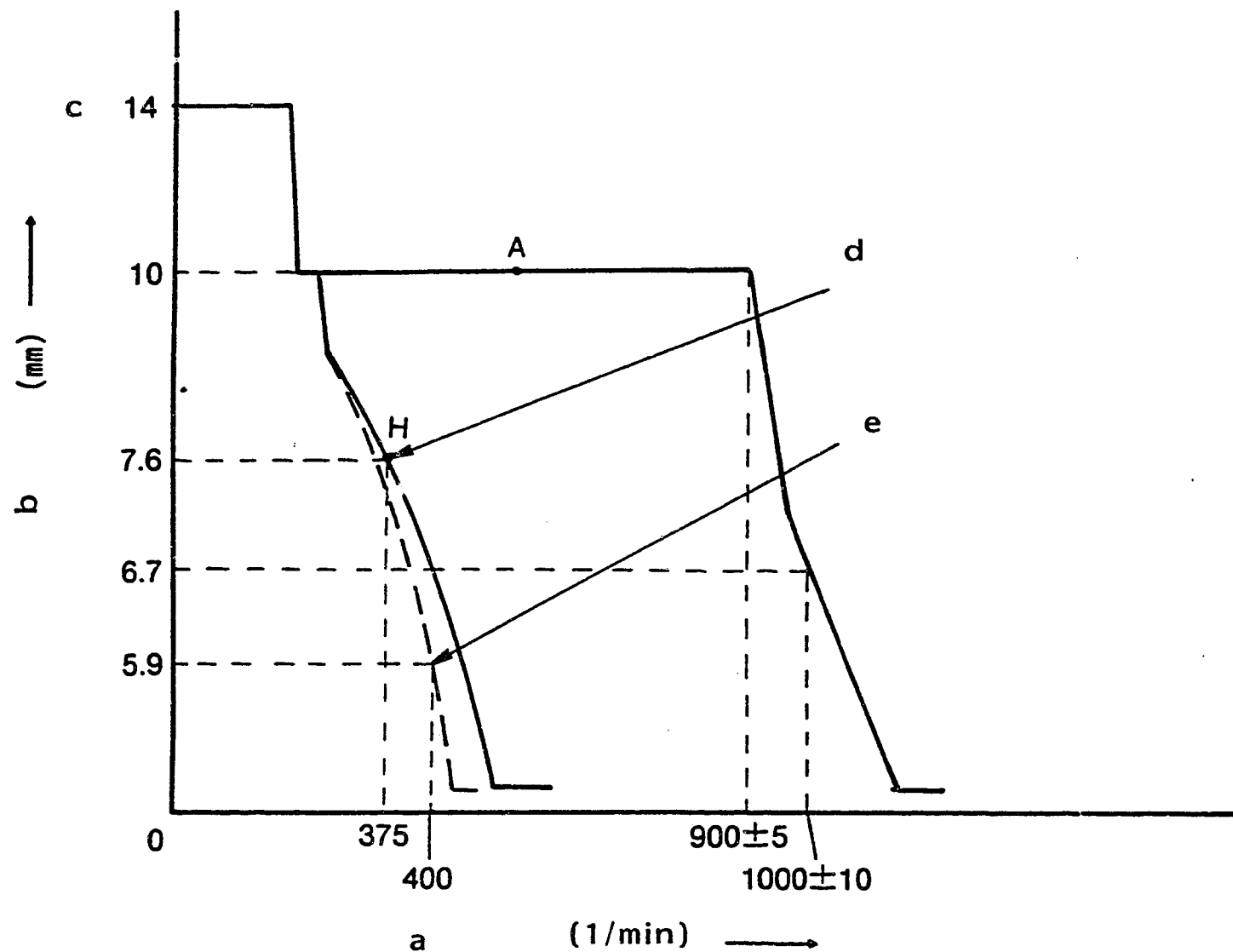

Figure 1

- a = Pump speed
- b = Control rack position
- c = above
- d = Idle-sub spring setting
- e = Governor spring setting

GOVERNOR ADJUSTMENT

Recommended speed droop adjustment screw position: 10

A = Speed control lever angle

- a = Idling
- b = Full-speed

B = Stop lever angle

- a = Normal
- b = Stop

Note

- Before adjustment, remove the idling sub spring and the torque control spring.
- Move the control lever fully in the stop direction, and set the minimum-speed stopper bolt so that the control rack position is 0.5 - 1.0 mm.

A4

ZEXEL - Test values
Injection pumps



A5

ZEXEL - Test values
Injection pumps



	Pump Speed (rpm)	Rack Position (mm)	Remarks
Full-load Adjustment (Temporary)	895 - 905	10.0	• Adjust using screw (1)
Full-load Adjustment	900	10.0	• Adjust using screw (2)
Maximum-speed Adjustment	895 - 905 990 - 1010	10.0 6.7	• Adjust using screw (1) • Adjust using spring capsule (5)
Idling Adjustment	400 375 -	5.9 7.6 -	• Fix the control lever • Adjust using idling-sub spring capsule (5) • Confirm
Control Lever Angle Measurement	<ul style="list-style-type: none"> • Measure the control lever angle at the "idling" and "full" positions. • When the control lever is depressed toward the "full" position, replace the shifter's shim with a thicker one. • When the control lever is depressed toward the "idling" position, replace the shifter's shim with a thinner one. 		

TIMING SETTING

At No. 1 plunger's beginning of injection position
B.T.D.C.: 16°

Figure 2
a = Pump center line

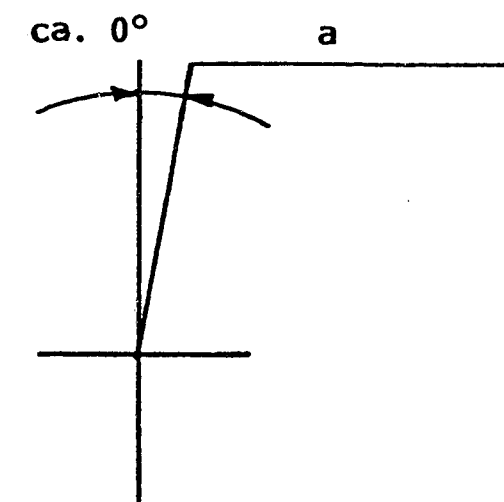

A6

ZEXEL - Test values
Injection pumps



A7

ZEXEL - Test values
Injection pumps



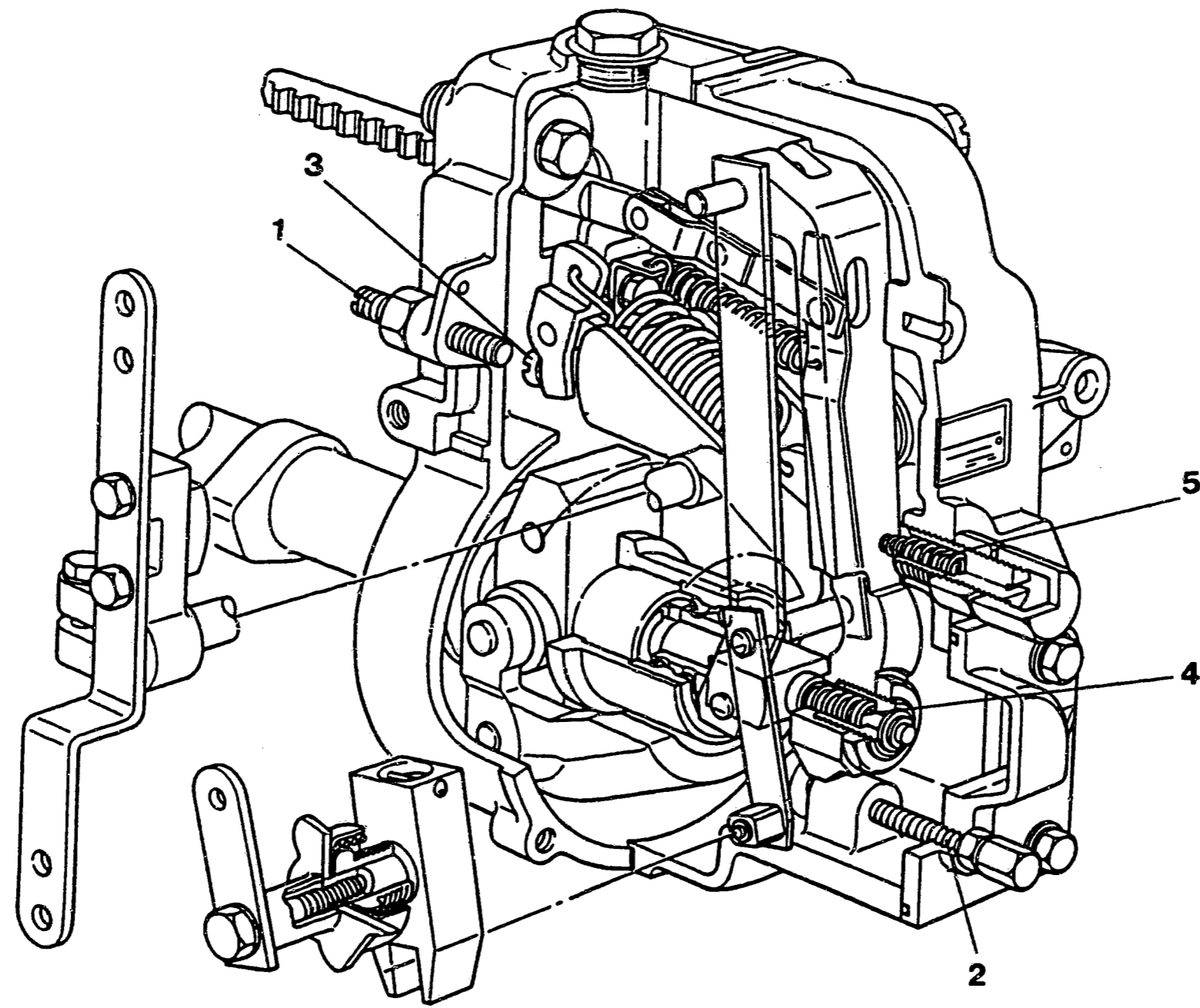

Figure 3

- 1 = Screw
- 2 = Screw
- 3 = Screw
- 4 = Spring capsule
- 5 = Spring capsule

A8

ZEXEL - Test values
Injection pumps



A9

ZEXEL - Test values
Injection pumps



Test oil:
ISO 4113 or
SAE J967d

ZEXEL-TEST VALUES
Distributors pumps
Engine model: NEW HA

BOSCH No.	9 460 610 474
ZEXEL No.	104740-0123
Date:	30.05.1991 [0]
Company:	MAZDA
No.	SE0913800A

Injection pump no. 104640-0123

(NP-VE4/10F1900RNP57)

Pump rot.: Clockwise-viewed from drive side

Test-nozzle holder combination:
1 688 901 000

Test pressure line:
1 680 750 017

1. Setting values		Speed (rpm)	Setting values	Charge-air pressure bar (mmHg)	Difference (cc)
1-1	Timing device travel	1500	5.0 - 5.4 (mm)		
1-2	Supply pump pressure	1500	5.7 - 6.3 (kg/cm ²)		
1-3	Full load delivery	1000	53.1 - 54.1 (cc/1000st)		3.5
	Full load delivery		(cc/1000st)		
1-4	Idle speed regulation	350	10.8 - 14.8 (cc/1000st)		2.5
1-5	Start	100	above 78.0 (cc/1000st)		
1-6	Full-load speed regulation	2100	19.1 - 25.1 (cc/1000st)		5.5
1-7					

2. Test values

2-1 Timing device	N = rpm mm	1000 1.6 - 2.8	1500 4.9 - 5.5	1900 7.0 - 8.2
2-2 Supply pump	N = rpm kg/cm ²	500 2.3 - 2.9	1500 5.7 - 6.3	1900 7.1 - 7.7
2-3 Overflow delivery	N = rpm cc/10s	1000 53.0 - 97.0		

2-4 Fuel injection quantities

Control lever position	Speed rpm	Fuel delivery (cc/1000 strokes)	Charge-air pres (mmHg)	Difference (cc)
End stop	1000	52.6 - 54.6		
	500	45.6 - 49.6		
	1500	50.3 - 54.3		
	1900	46.4 - 50.4		
	2100	19.1 - 25.1		
	2200	below 6.0		
Switch off	350	0		
Idle stop	350	10.8 - 14.8		
	below 620	0		

2-5 Solenoid
Cut-in voltage max.: 8V
Test voltage: 12 - 14V

3. Dimensions

K	3.2 - 3.4 mm
KF	5.7 - 5.9 mm
MS	1.7 - 1.9 mm
BCS	- mm
Pre-str.	0.18 - 0.22 mm
Control lever angle	
α	18.0 - 22.0 deg
A	35.9 - 38.6 mm
β	33.0 - 43.0 deg
B	10.2 - 13.9 mm
γ	- deg
C	- mm

A10

ZEXEL - Test values
Injection pumps



A11

ZEXEL - Test values
Injection pumps



Test oil:
ISO 4113 or
SAE J967d

ZEXEL-TEST VALUES
Distributors pumps
Engine model: CD20

1/4

BOSCH No. 9 460 610 478
ZEXEL No. 104740-2184
Date: 30.05.1991 [0]
Company: NISSAN
No. 1670057J00

Injection pump no. 104640-2184 (NP-VE4/10F2500LNP865)

Pump rotation.: Counter clockwise-viewed
from drive side

Test-nozzle holder combination:
1 688 901 022

Test pressure line:
1 680 750 073

1. Setting values	Speed (rpm)	Setting values	Charge-air pressure bar (mmHg)	Difference (cc)
1-1 Timing device travel	1000	2.5 - 2.9 (mm)		
1-2 Supply pump pressure	1000	3.9 - 4.5 (kg/cm ²)		
1-3 Full load delivery	1400	36.7 - 37.7 (cc/1000st)		3.0
1-4 Idle speed regulation	350	9.5 - 11.5 (cc/1000st)		2.0
1-5 Start	100	50.0 - 70.0 (cc/1000st)		
1-6 Full-load speed regulation	2700	12.0 - 16.0 (cc/1000st)		4.5
1-7				

2. Test values

2-1 Timing device	N = rpm mm	1000 2.4 - 3.0	1800 5.8 - 7.0	2400 8.0 - 9.0
2-2 Supply pump	N = rpm kg/cm ²	1000 3.9 - 4.5	1800 5.6 - 6.4	2400 7.1 - 7.9
2-3 Overflow delivery	N = rpm cc/10s	1000 43.0 - 97.0		

2-4 Fuel injection quantities

Control lever position	Speed rpm	Fuel delivery (cc/1000 strokes)	Charge-air pres (mmHg)	Difference (cc)
End stop	1400	36.2 - 38.2		
	600	29.8 - 34.8		
	1000	31.3 - 36.3		
	1800	36.1 - 40.1		
	2400	34.7 - 39.7		
	2700	11.5 - 16.5		
	2800	below 5.0		
Switch off	350	0		
Idle stop	700	below 5.0		
	350	9.5 - 11.5		
Partial load	700	12.0 - 24.0		

2-5 Solenoid
Cut-in voltage max.: 8V
Test voltage: 12 - 14V

3. Dimensions

K 3.2 - 3.4 mm
KF 6.68 - 6.88 mm
MS 0.7 - 0.9 mm
BCS - mm
Pre-str. - mm

Control lever angle

α 23° - 27° deg
A 14.1 - 19.4 mm
β 39° - 49° deg
B 12.2 - 15.7 mm
γ 10.5° - 11.5° deg
C 6.8 - 7.4 mm

A12

ZEXEL - Test values
Injection pumps



A13

ZEXEL - Test values
Injection pumps



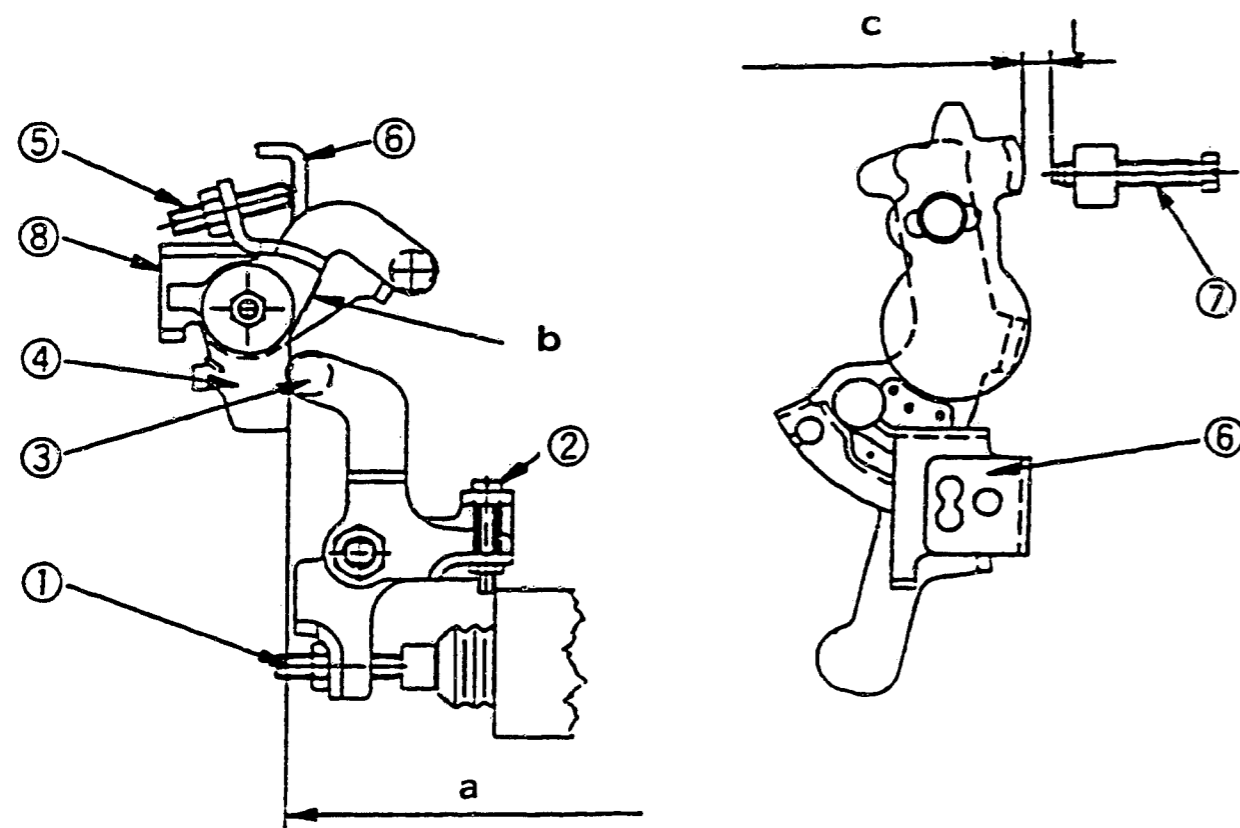

Figure 4

a = Vertical position
b = Aligning mark

c = Block gauge

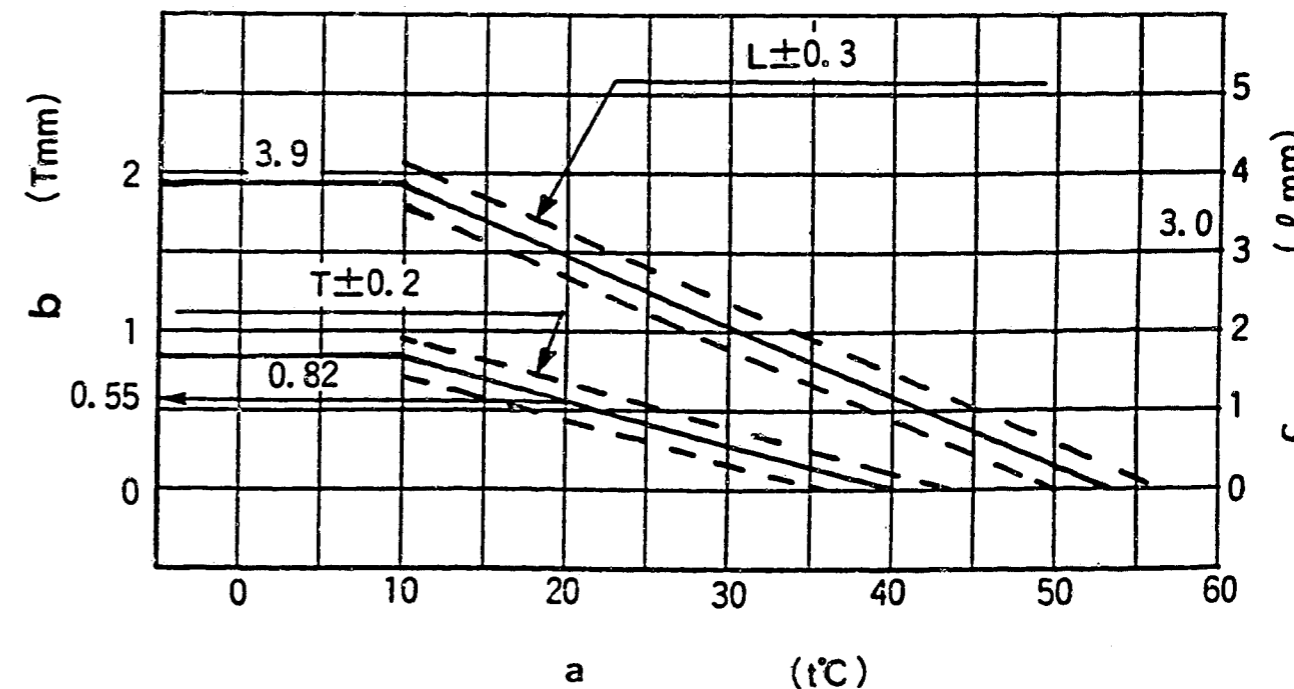

Figure 5

104740-2184 2/4

a = Atmospheric temperature
b = Timer stroke
c = Gap between control lever and idling stopper bolt

W-CSD ADJUSTMENT

1. Timer Stroke Adjustment (adjust to the thick line)

- 1) Calculate the timer stroke from Fig. 5 according to the atmospheric temperature at the time of adjustment.
- 2) Adjust using the timer stroke adjusting screw so that the timer stroke is as calculated in Fig. 5 (diagram).

A14

ZEXEL - Test values
Injection pumps



A15

ZEXEL - Test values
Injection pumps



(Continued)

2. Intermediate Lever Position Adjustment

- 1) Insert a block gauge (thickness gauge) of 3.0 ± 0.05 mm thickness between the control lever and the idling stopper bolt.
- 2) Insert a block gauge (thickness gauge) of 5.3 ± 0.05 mm thickness between the intermediate lever and the intermediate lever bracket.
- 3) Align the intermediate lever with the aligning mark.
- 4) Adjust the intermediate lever set screw so that the control lever and the intermediate lever set screw are in contact, and then fix in position using the locknut.

A16

ZEXEL - Test values

Injection pumps



3. CSD Lever Adjustment (adjust to the thick line)

- 1) Calculate the block gauge dimension $l \pm 0.05$ mm from (Fig. 5) according to the atmospheric temperature at the time of adjustment.
- 2) Insert the block gauge (thickness gauge) between the control lever and the idling stopper bolt.
- 3) Using the idling bolt, adjust so that the CSD lever roller and the intermediate lever are in contact.

4. Final Adjustment

After completing the adjustment, screw the timer stroke adjusting screw two turns clockwise.
(Move from the temporary adjustment chart to the final adjustment chart).

Note:

1. The temperature of the wax must be below 30°C when adjusting.
2. When inserting a block gauge (thickness gauge) between the control lever (bracket) and the idling stopper bolt, use the idling adjusting bolt to separate the CSD lever and the intermediate lever so that no excessive force is exerted on them.

θ (°C) \leq 10	TA = 0.82	θ (°C) \leq 10	L = 3.9
$10 \leq \theta$ (°C) \leq 20	TA = -0.027 θ + 1.09	$10 \leq \theta$ (°C) \leq 30	L = -0.09 θ + 4.8
$20 \leq \theta$ (°C) \leq 40	TA = -0.0275 θ + 1.1	$30 \leq \theta$ (°C) \leq 54.3	L = -0.086 θ + 4.68

A17

ZEXEL - Test values
Injection pumps

**A18**

ZEXEL - Test values
Injection pumps



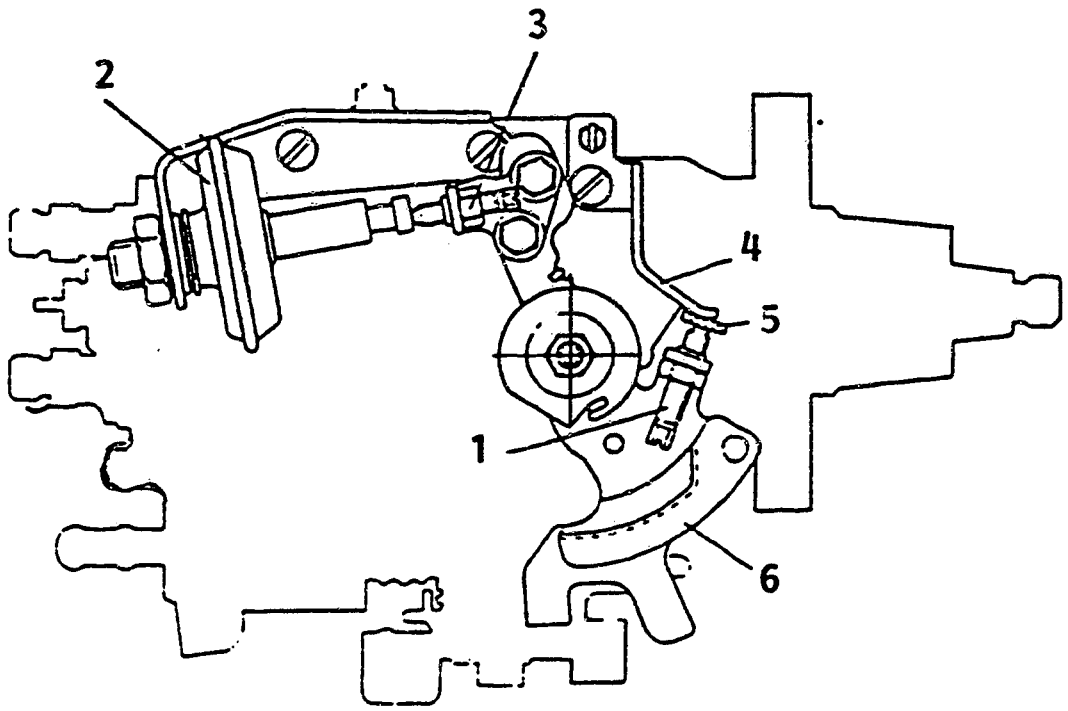

Figure 6

104740-2184 4/4

- 1 = Idling stopper bolt
- 2 = Dashpot
- 3 = Dashpot adjusting screw
- 4 = Bracket
- 5 = Block gauge
- 6 = Control lever

■ DASH POT ADJUSTMENT

1. Insert a block gauge (thickness gauge) of thickness $6.0 \pm 0,05$ mm in the gap between the bracket and the idling stopper bolt.



(Continued)

2. With the control lever positioned as described in point 1., adjust the dashpot adjusting screw so that the dashpot adjusting screw and the push rod are in contact.

Fix the screw using the nut.

3. Adjust the dash pot mounting position so that the dash pot of the tip and the control lever are in contact. Fix the dash pot using the nut.

Caution:

- The adjusting screw and the pushrod must move together smoothly.
- Confirm that the control lever returns to the idling position.

A 20

ZEXEL - Test values

Injection pumps



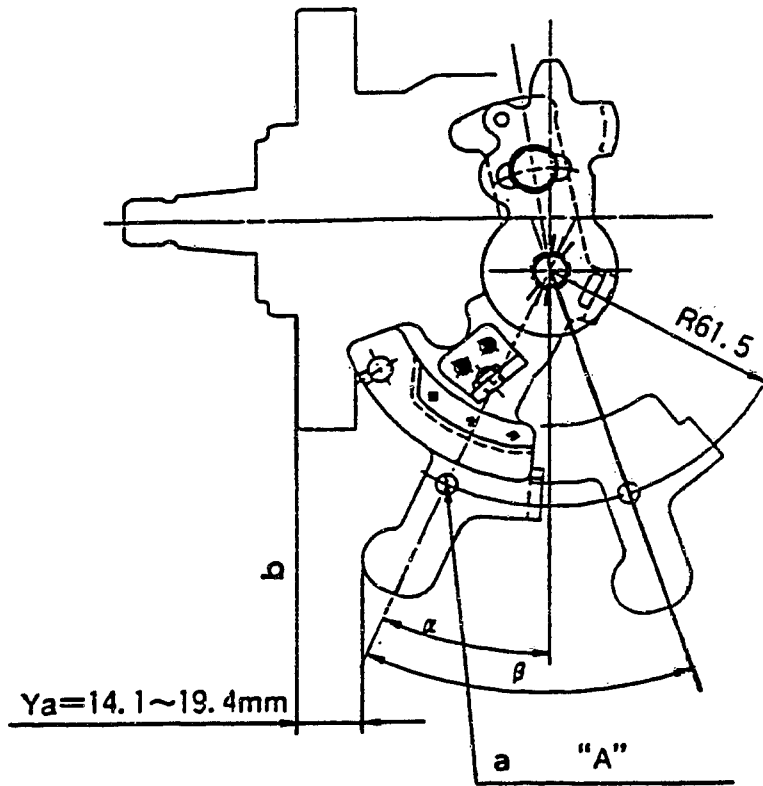

104740-2184 4/4

(Continued)

Figure 7

a = Measurement position
 b = End face of flange

■ CONTROL LEVER ANGLE MEASUREMENT POSITION

- 1) Measure the control lever angles (α , β , γ) at hole "A".

A21

ZEXEL - Test values
 Injection pumps



Test oil:
ISO 4113 or
SAE J967d

ZEXEL-TEST VALUES
Distributors pumps
Engine model: CD20

1/4

BOSCH No. 9 460 610 479
ZEXEL No. 104740-2194
Date: 30.05.1991 [0]
Company: NISSAN
No. 1670057J05

Injection pump no. 104640-2191 (NP-VE4/10F2500LNP865)

Pump rotation.: Counter clockwise-viewed
from drive side

Test-nozzle holder combination:
1 688 901 022

Test pressure line:
1 680 750 073

1. Setting values		Speed (rpm)	Setting values	Charge-air pressure bar (mmHg)	Difference (cc)
1-1	Timing device travel	1000	2.5 - 2.9 (mm)		
1-2	Supply pump pressure	1000	3.9 - 4.5 (kg/cm ²)		
1-3	Full load delivery	1400	36.7 - 37.7 (cc/1000st)		3.0
	Full load delivery		(cc/1000st)		
1-4	Idle speed regulation	350	9.5 - 11.5 (cc/1000st)		2.0
1-5	Start	100	50.0 - 70.0 (cc/1000st)		
1-6	Full-load speed regulation	2700	12.0 - 16.0 (cc/1000st)		4.5
1-7					

2. Test values

2-1 Timing device	N = rpm	1000	1800	2400
	mm	2.4 - 3.0	5.8 - 7.0	8.0 - 9.0
2-2 Supply pump	N = rpm	1000	1800	2400
	kg/cm ²	3.9 - 4.5	5.6 - 6.4	7.1 - 7.9
2-3 Overflow delivery	N = rpm	1000		
	cc/10s	43.0 - 97.0		

2-4 Fuel injection quantities

Control lever position	Speed rpm	Fuel delivery (cc/1000 strokes)	Charge-air pres (mmHg)	Difference (cc)
End stop	1400	36.2 - 38.2		
	600	29.8 - 34.8		
	1000	31.3 - 36.3		
	1800	36.1 - 40.1		
	2400	34.7 - 39.7		
	2700	11.5 - 16.5		
	2800	below 5.0		
Switch off	350	0		
Idle stop	700	below 5.0		
	350	9.5 - 11.5		
Partial load	700	12.0 - 24.0		

2-5 Solenoid
Cut-in voltage max.: 8V
Test voltage: 12 - 14V

3. Dimensions

K 3.2 - 3.4 mm
KF 6.68 - 6.88 mm
MS 0.7 - 0.9 mm
BCS - mm
Pre-str. - mm

Control lever angle

α 23° - 27° deg
A 14.1 - 19.4 mm
 β 39° - 49° deg
B 12.2 - 15.7 mm
 γ 10.5° - 11.5° deg
C 6.8 - 7.4 mm

B1

ZEXEL - Test values
Injection pumps



B2

ZEXEL - Test values
Injection pumps



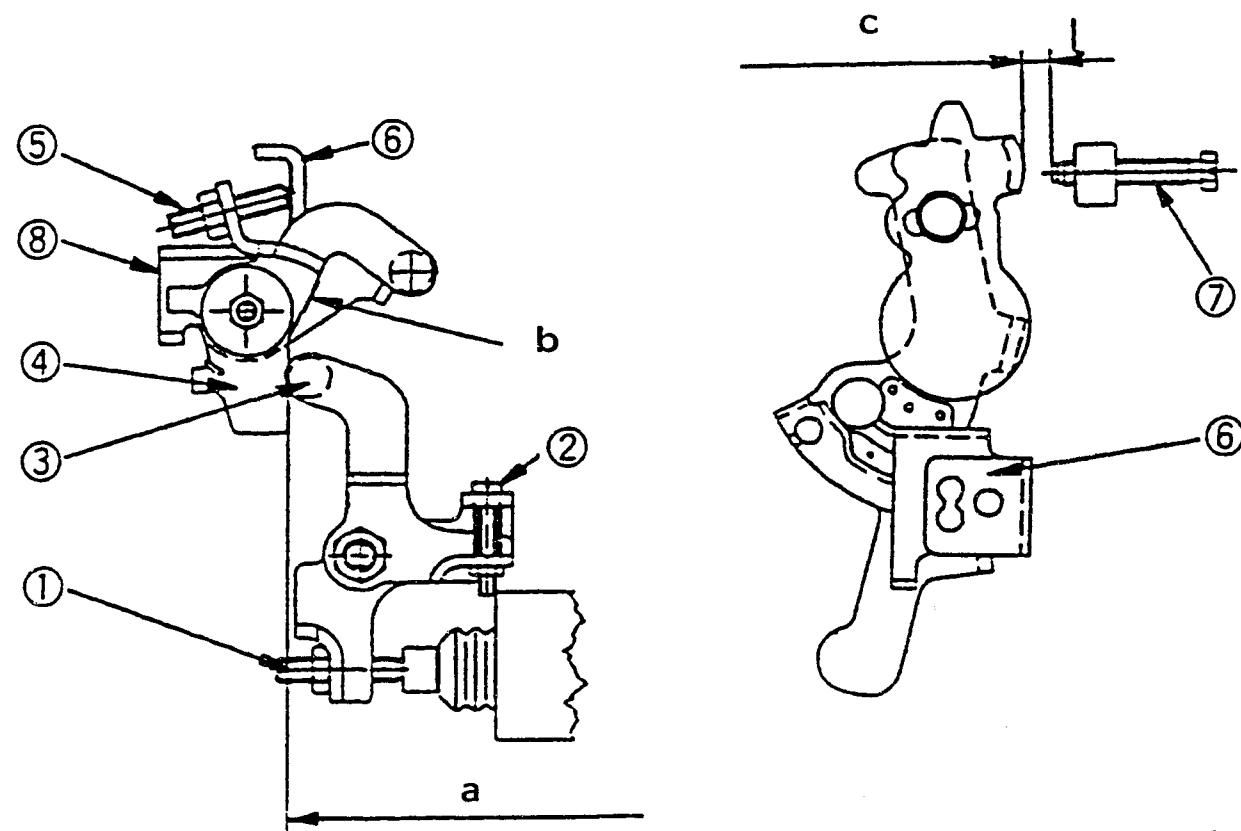

Figure 8

a = Vertical position
b = Aligning mark

c = Block gauge

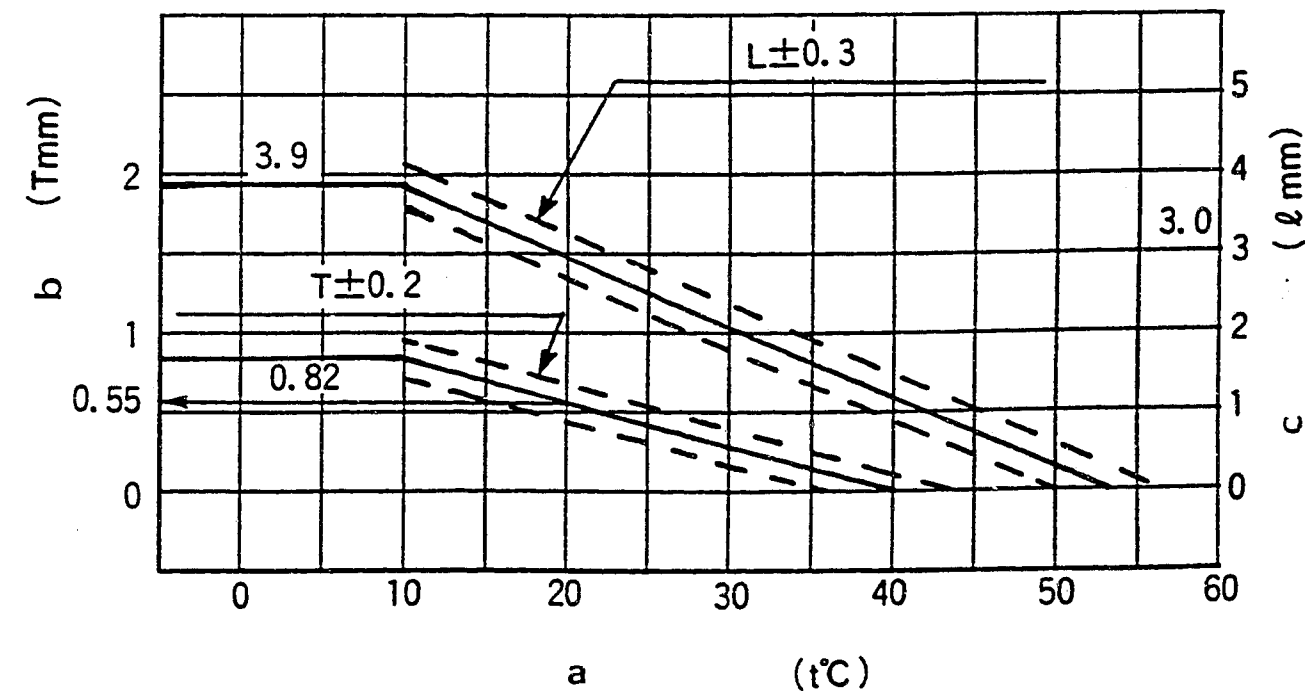

Figure 9

104740-2194 2/4

a = Atmospheric temperature
b = Timer stroke
c = Gap between control lever
and idling stopper bolt

W-CSD ADJUSTMENT

1. Timer Stroke Adjustment (adjust to the thick line)

- 1) Calculate the timer stroke from Fig. 9 according to the atmospheric temperature at the time of adjustment.
- 2) Adjust using the timer stroke adjusting screw so that the timer stroke is as calculated in Fig. 9 (diagram).

B3

ZEXEL - Test values
Injection pumps



B4

ZEXEL - Test values
Injection pumps



(Continued)

2. Intermediate Lever Position Adjustment

- 1) Insert a block gauge (thickness gauge) of 3.0 ± 0.05 mm thickness between the control lever and the idling stopper bolt.
- 2) Insert a block gauge (thickness gauge) of 5.3 ± 0.05 mm thickness between the intermediate lever and the intermediate lever bracket.
- 3) Align the intermediate lever with the aligning mark.
- 4) Adjust the intermediate lever set screw so that the control lever and the intermediate lever set screw are in contact, and then fix in position using the locknut.

B5

ZEXEL - Test values

Injection pumps



3. CSD Lever Adjustment (adjust to the thick line)

- 1) Calculate the block gauge dimension $l \pm 0.05$ mm from (Fig. 9) according to the atmospheric temperature at the time of adjustment.
- 2) Insert the block gauge (thickness gauge) between the control lever and the idling stopper bolt.
- 3) Using the idling bolt, adjust so that the CSD lever roller and the intermediate lever are in contact.

4. Final Adjustment

After completing the adjustment, screw the timer stroke adjusting screw two turns clockwise.
(Move from the temporary adjustment chart to the final adjustment chart).

Note:

1. The temperature of the wax must be below 30°C when adjusting.
2. When inserting a block gauge (thickness gauge) between the control lever (bracket) and the idling stopper bolt, use the idling adjusting bolt to separate the CSD lever and the intermediate lever so that no excessive force is exerted on them.

θ (°C) \leq 10	TA = 0.82	θ (°C) \leq 10	L = 3.9
$10 \leq \theta$ (°C) \leq 20	TA = -0.027 θ + 1.09	$10 \leq \theta$ (°C) \leq 30	L = -0.09 θ + 4.8
$20 \leq \theta$ (°C) \leq 40	TA = -0.0275 θ + 1.1	$30 \leq \theta$ (°C) \leq 54.3	L = -0.086 θ + 4.68

B6

ZEXEL - Test values
Injection pumps

**B7**

ZEXEL - Test values
Injection pumps



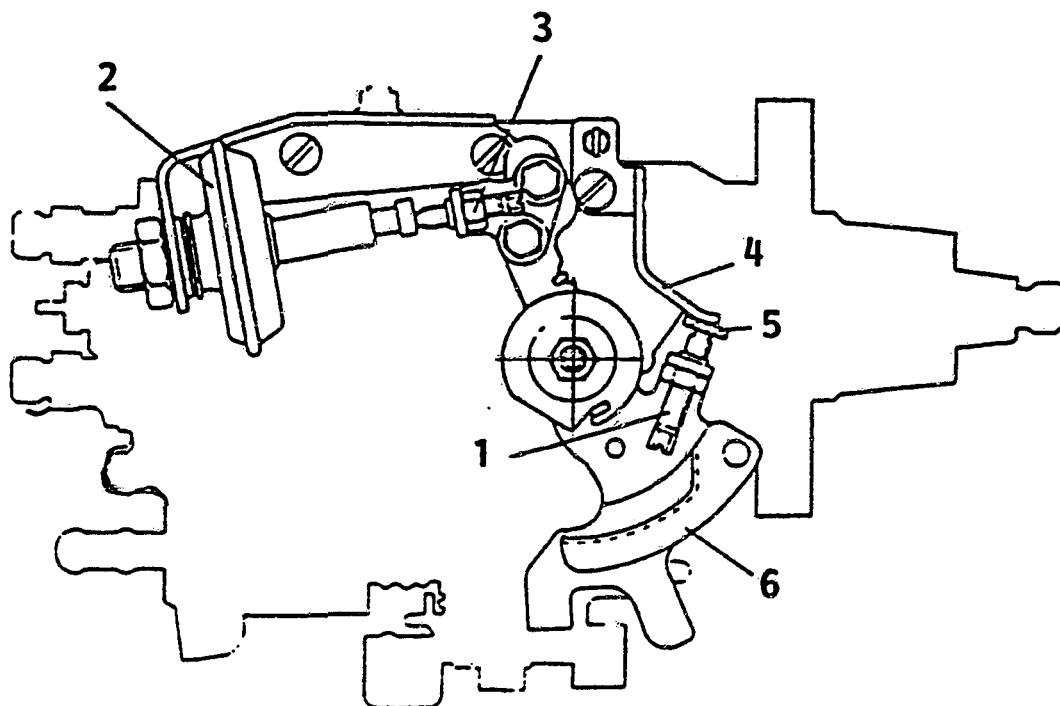

Figure 10

104740-2194 4/4

- 1 = Idling stopper bolt
- 2 = Dashpot
- 3 = Dashpot adjusting screw
- 4 = Bracket
- 5 = Block gauge
- 6 = Control lever

■ DASH POT ADJUSTMENT

1. Insert a block gauge (thickness gauge) of thickness $6.0 \pm 0,05$ mm in the gap between the bracket and the idling stopper bolt.



(Continued)

2. With the control lever positioned as described in point 1., adjust the dashpot adjusting screw so that the dashpot adjusting screw and the push rod are in contact.

Fix the screw using the nut.

3. Adjust the dash pot mounting position so that the dash pot of the tip and the control lever are in contact. Fix the dash pot using the nut.

Caution:

- The adjusting screw and the pushrod must move together smoothly.
- Confirm that the control lever returns to the idling position.

B9

ZEXEL - Test values

Injection pumps



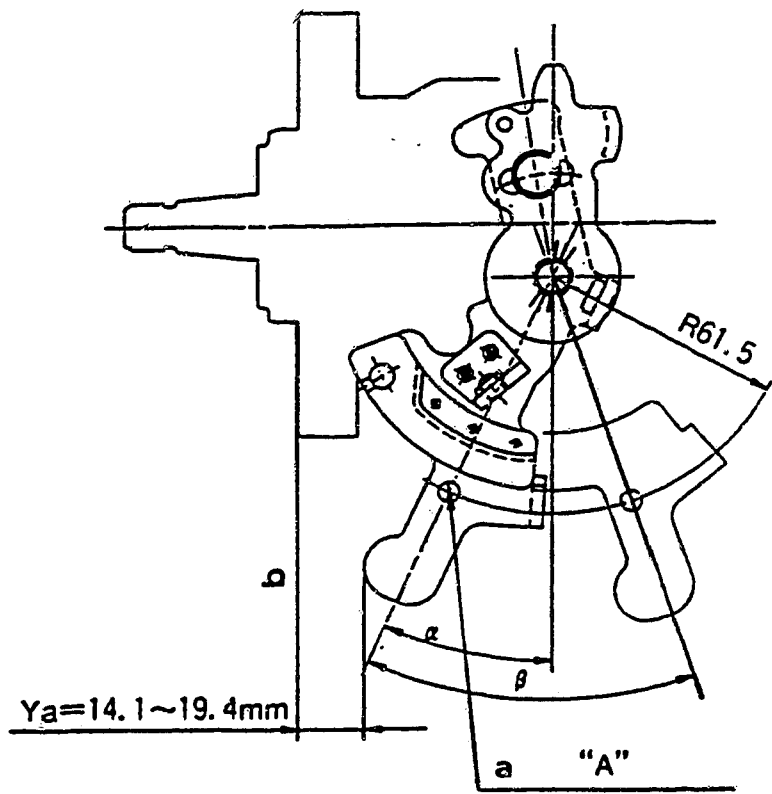

104740-2194 4/4

(Continued)

Figure 11

a = Measurement position
 b = End face of flange

■ CONTROL LEVER ANGLE MEASUREMENT POSITION

- 1) Measure the control lever angles (α , β , γ) at hole "A".



Test oil:
ISO 4113 or
SAE J967d

ZEXEL-TEST VALUES
Distributors pumps
Engine model: CD20

1/6

BOSCH No. 9 460 610 480
ZEXEL No. 104740-2224
Date: 30.05.1991 [0]
Company: NISSAN
No. 1670060J00

Injection pump no. 104640-2224 (NP-VE4/10F2500LNP867)

Pump rotation.: Counter clockwise-viewed from drive side
Test-nozzle holder combination: 1 688 901 022
Test pressure line: 1 680 750 073

1. Setting values		Speed (rpm)	Setting values	Charge-air pressure bar (mmHg)	Difference (cc)
1-1	Timing device travel	1000	2.5 - 2.9 (mm)		
1-2	Supply pump pressure	1000	3.9 - 4.5 (kg/cm ²)		
1-3	Full load delivery	1400	36.7 - 37.7 (cc/1000st)		3.0
	Full load delivery		(cc/1000st)		
1-4	Idle speed regulation	350	9.5 - 11.5 (cc/1000st)		2.0
1-5	Start	100	50.0 - 70.0 (cc/1000st)		
1-6	Full-load speed regulation	2700	12.0 - 16.0 (cc/1000st)		4.5
1-7					

2. Test values

2-1 Timing device	N = rpm mm	1000 2.4 - 3.0	1800 5.8 - 7.0	2400 8.0 - 9.0
2-2 Supply pump	N = rpm kg/cm ²	1000 3.9 - 4.5	1800 5.7 - 6.3	2400 7.1 - 7.9
2-3 Overflow delivery	N = rpm cc/10s	1000 43.0 - 87.0		

2-4 Fuel injection quantities

Control lever position	Speed rpm	Fuel delivery (cc/1000 strokes)	Charge-air pres (mmHg)	Difference (cc)
End stop	1400	36.2 - 38.2		
	600	30.9 - 34.9		
	1000	30.5 - 34.5		
	1800	36.1 - 40.1		
	2400	35.7 - 39.7		
	2700	11.5 - 16.5		
	2800	below 5.0		
Switch off	350	0		
Idle stop	750	below 5.0		
	350	9.5 - 11.5		
Partial load	700	12.0 - 24.0		

2-5 Solenoid
Cut-in voltage max.: 8V
Test voltage: 12 - 14V

3. Dimensions

K 3.2 - 3.4 mm
KF 6.68 - 6.88 mm
MS 0.7 - 0.9 mm
BCS - mm
Pre-str. - mm

Control lever angle

α 23° - 27° deg
A 14.1 - 19.4 mm
 β 39° - 49° deg
B 12.2 - 15.7 mm
 γ 15.6° - 16.6° deg
C 10.0 - 10.7 mm

B11

ZEXEL - Test values
Injection pumps



B12

ZEXEL - Test values
Injection pumps



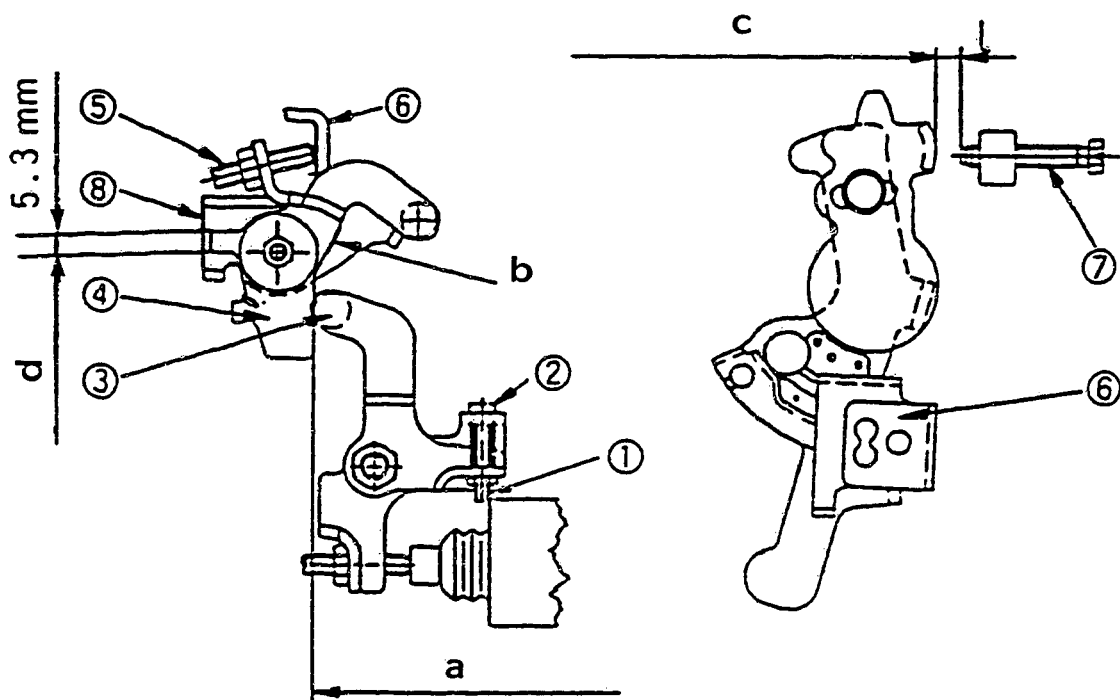

Figure 12

104740-2224 2/6

a = Vertical position
b = Aligning mark

c = Block gauge
d = Shim

■ W-CSD Adjustment

1. Intermediate Lever Position Adjustment

- 1) Insert a block gauge (thickness gauge) of 3.0 ± 0.05 mm thickness between the control lever and the idling stopper bolt.
- 2) Insert a shim of 5.3 ± 0.05 mm thickness between the bracket and the intermediate lever.
- 3) Adjust the intermediate lever set screw so that the control lever and the intermediate lever set screw are in contact, and then fix in position using the locknut.



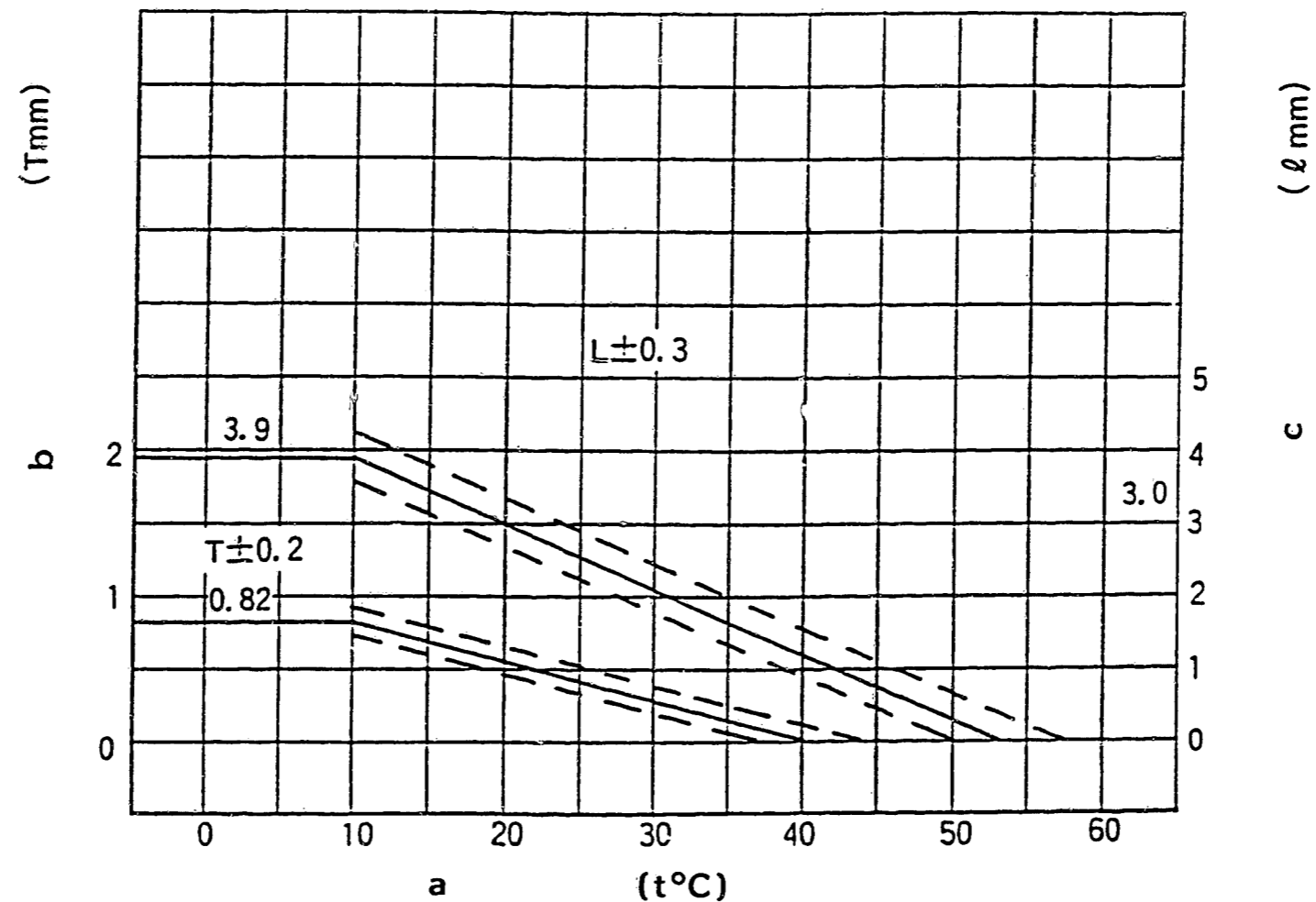

Figure 13

104740-2224 3/6

- a = Atmospheric temperature
- b = Timer stroke
- c = Gap between control lever and idling stopper bolt

2. CSD Lever Adjustment (adjust to the thick line)

- 1) Calculate the block gauge dimension $l \pm 0.05$ mm from (Fig. 13) according to the atmospheric temperature at the time of adjustment.
- 2) Insert the block gauge (thickness gauge) between the control lever and the idling stopper bolt.
- 3) In the above condition, adjust screw (2) so that the intermediate lever setting screw contacts the control lever. Then, tighten nut (1) to fix the screw.

B14

ZEXEL - Test values

Injection pumps



B15

ZEXEL - Test values

Injection pumps



Note:

1. The temperature of the wax must be below 30°C when adjusting.

θ (°C) \leq 10	TA = 0.82	θ (°C) \leq 10	L = 3.9
$10 \leq \theta$ (°C) \leq 20	TA = -0.027 θ + 1.09	$10 \leq \theta$ (°C) \leq 30	L = -0.09 θ + 4.8
$20 \leq \theta$ (°C) \leq 40	TA = -0.0275 θ + 1.1	$30 \leq \theta$ (°C) \leq 54.3	L = -0.086 θ + 4.68

B16

ZEXEL - Test values
Injection pumps



B17

ZEXEL - Test values
Injection pumps



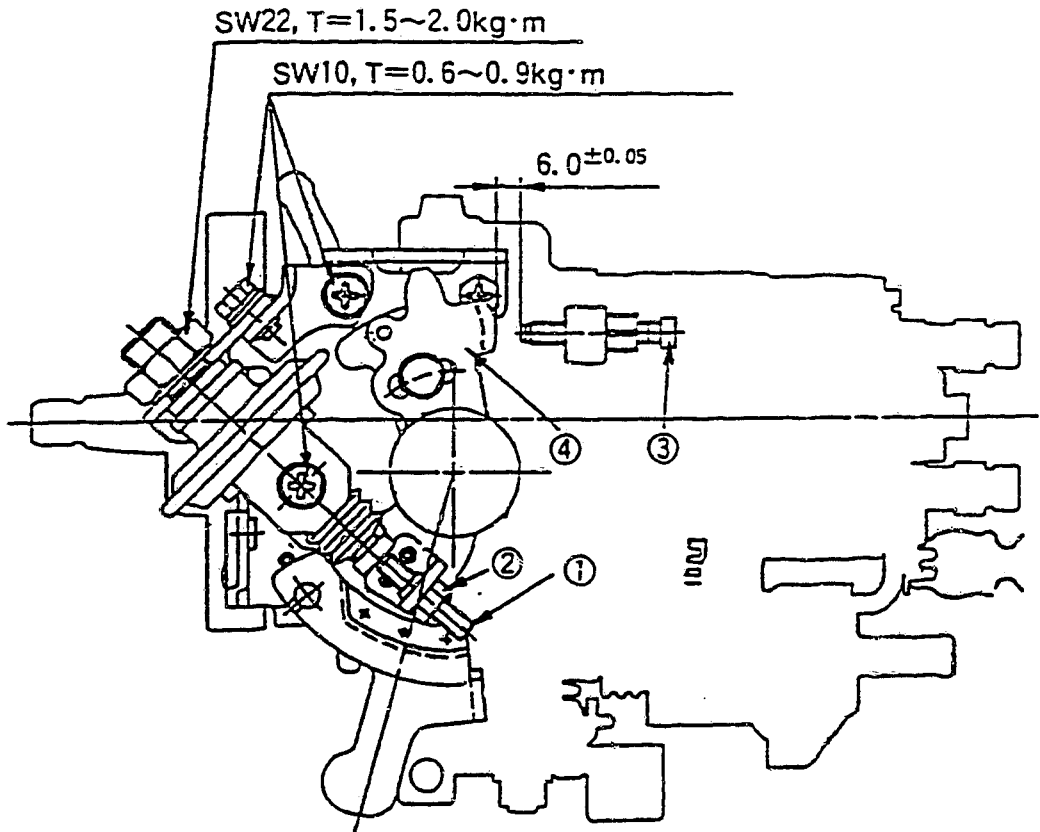

Figure 14

104740-2224 4/6

■ DASH POT ADJUSTMENT

1. Insert a block gauge (thickness gauge) of thickness 6.0 ± 0.05 mm in the gap between the control lever and the idling stopper bolt.
2. With the control lever positioned as described in point 1. above, adjust the dashpot adjusting screw so that the dashpot adjusting screw and the push rod are in contact.
Fix the screw using the nut.

Caution:

- The adjusting screw and the pushrod must move together smoothly.
- Confirm that the control lever returns to the idling position.

B18

ZEXEL - Test values
Injection pumps



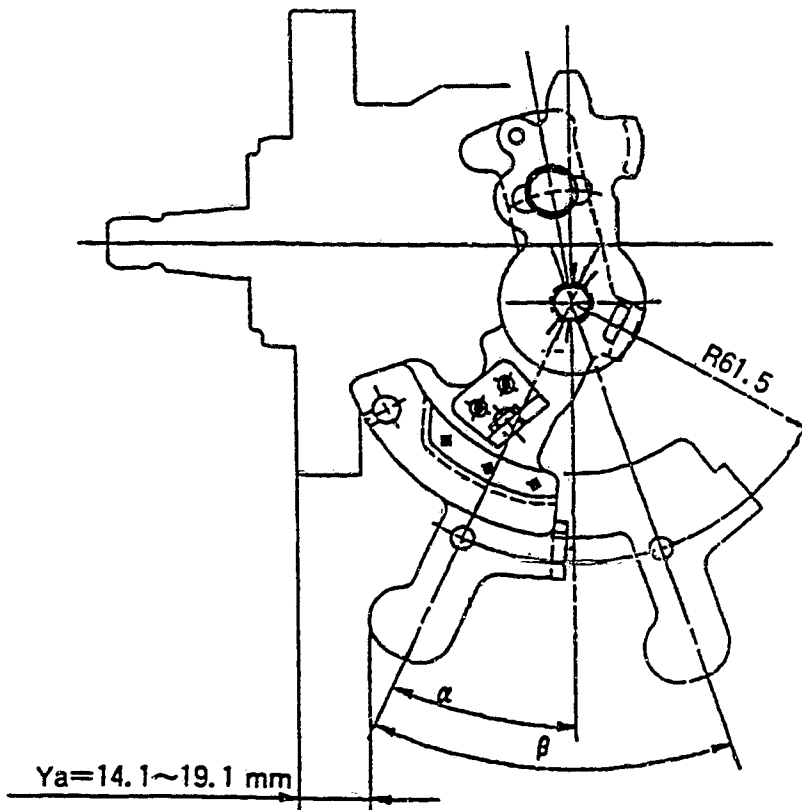

Figure 15

104740-2224 5/6

■ CONTROL LEVER ANGLE MEASUREMENT POSITION

B19

ZEXEL - Test values

Injection pumps



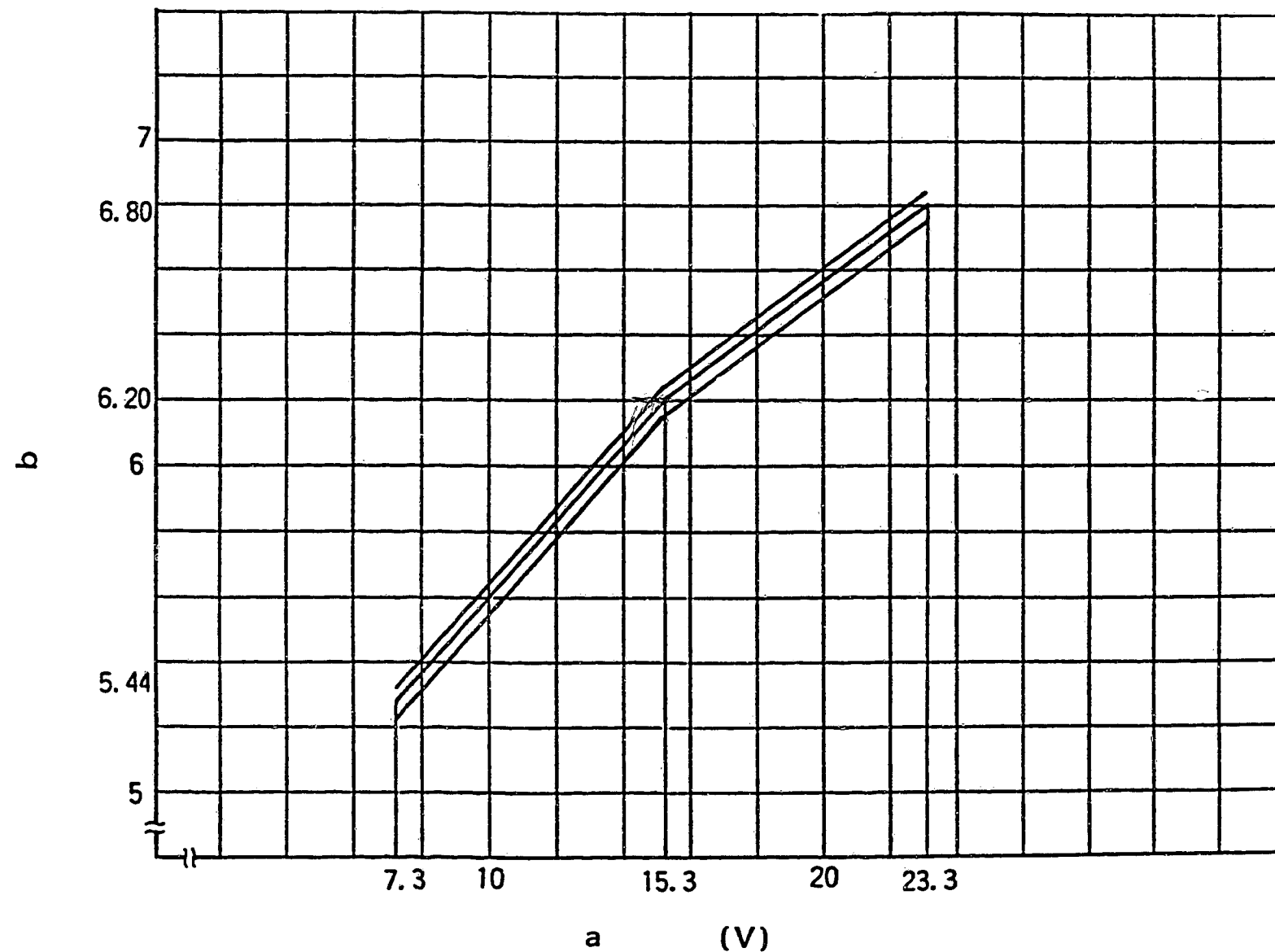

Figure 16

a = Out-put voltage

b = Fuel injection quantity (cm³/1000st)

■ POTENTIOMETER ADJUSTMENT

Fuel injection quantity $Q < 14.2 \text{ cm}^3/1000\text{st}$ $\rightarrow V \pm 0.03 = 0.0978 Q + 4.7259$

Fuel injection quantity $Q \geq 14.2 \text{ cm}^3/1000\text{st}$ $\rightarrow V \pm 0.03 = 0.0752 Q + 5.0457$

B20

ZEXEL - Test values

Injection pumps



B21

ZEXEL - Test values

Injection pumps



Under the following conditions, alter the potentiometer's installation position so that the out-put voltage equals the specified value.

Adjustment Conditions			Specified Value	Remarks
Control lever position	Pump speed (rpm)	Fuel injection quantity (cc/1000st)	Out-put voltage (V)	
Approx. 16.1°	1200	Measure	Measure	Adjust. point
Idle	-	-	-	Check point
Full speed	-	-	-	Check point

(In-put voltage: 10V)

* A control lever position of approx. 16.1° means that a block gauge of 10.3 mm thickness is inserted between the control lever and the idling stopper bolt.

B 22

ZEXEL - Test values
Injection pumps



B 23

ZEXEL - Test values
Injection pumps



Test oil
ISO 4113 or
SAE J967d

ZEXEL - TEST VALUES
Distributor pumps
Engine model: 4D56

1/2

BOSCH No.	9 460 610 467
ZEXEL No.	104740-3633
Date:	30.05.1991 [0]
Company:	mitsubishi
No.	MD103206

Injection pump no.: 104640-3343 (NP-VE4/10F2100RNP432)

Pump rot.: Clockwise-viewed from drive side Test-nozzle holder combination: 1 688 901 000 Test pressure line: 1 680 750 017

1. Setting values	Speed (rpm)	Setting values	Charge-air pressure bar (mmHg)	Difference in delivery (cc)
1-1 Timing device travel	1250	3.5 - 3.9 (mm)		
1-2 Supply pump pressure	1250	4.5 - 5.1 (kg/cm ²)		
1-3 Full load delivery	1250	45.3 - 46.3 (cc/1000st)		3.0
Full load delivery		- (cc/1000st)		
1-4 Idle speed regulation	375	6.5 - 9.5 (cc/1000st)		2.0
1-5 Start	100	63.0 - 83.0 (cc/1000st)		
1-6 Full-load speed regulation	2550	15.1 - 21.1 (cc/1000st)		4.0
1-7 Load-timer adjustment	1250	T = 0.4-0.8 (mm)		

2. Test values

2-1 Timing device	N = rpm	500	750	1250	2100
	mm	0.6-1.8	1.4-2.6	3.3-4.1	6.6-7.8
2-2 Supply pump	N = rpm	600		1250	2100
	kg/cm ²	2.9 - 3.5		4.5-5.1	6.5-7.1
2-3 Overflow delivery	N = rpm			1250	
	cc/10s			48.0-92.0	

2-4 Fuel injection quantities

Speed control lever pos.	Speed (rpm)	Fuel delivery (cc/1000st)	Charge-air pres(mmHg)	Difference in delivery (cc)
End stop	1250	44.8 - 46.8		
	600	42.3 - 46.3		
	2100	37.2 - 41.2		
	2550	13.1 - 23.1		
	2900	below 5.0		
Switch off	375	0		
Idle-stop	600	below 3.0		
	375	6.0 - 10.0		

2-5 Solenoid Cut-in voltage max. 8 V Test voltage: 12 - 14 V

3. Dimensions

K	3.2 - 3.4 mm
KF	5.7 - 5.9 mm
MS	1.1 - 1.3 mm
BCS	- mm
Pre-st.	- mm
Control lever angle	
α	55 - 63° deg
A	10.5 - 16.0 mm
β	41 - 51° deg
B	12.5 - 16.5 mm
γ	- deg
C	- mm

1. Adjustment

1) Fix the control lever in the position satisfying the following conditions:

Boost Pressure: - mmHg
 Pump Speed : 1250 rpm
 Fuel Injection Quantity: 35.2 - 36.2 cc/1000st

2) With the control lever positioned as described in 1) above, adjust the governor sleeve so that the Timer Stroke conforms to the specified values (page 1/2)

2. Confirmation of Timer Characteristics

Fix the control lever in the position satisfying the following conditions, and confirm the Timer Stroke.

Control lever position			Specified values	
Pump speed (rpm)	Fuel injection quantity (cc/1000st)	Boost pressure (mmHg)	Timer stroke (mm)	Timer stroke reduction value (mm)
1250	34.7 - 36.7	-	(3.1)	0.2 - 1.0
1250	26.7 - 29.7	-	(2.3)	0.8 - 2.0



Test oil
ISO 4113 or
SAE J967d

ZEXEL - TEST VALUES
Distributor pumps
Engine model: 4D56

1/3

BOSCH No.	9 460 610 490
ZEXEL No.	104740-8100
Date:	31.05.1991 [0]
Company:	mitsubishi
No.	MD163890

Injection pump no.: 104640-8100 (NP-VE4/10F2100RNP926)

Pump rot.: Clockwise-viewed from drive side Test-nozzle holder combination: 1 688 901 000 Test pressure line: 1 680 750 017

1. Setting values	Speed (rpm)	Setting values	Charge-air pressure bar (mmHg)	Difference in delivery (cc)
1-1 Timing device travel	1250	3.5 - 3.9 (mm)	540 - 560	
1-2 Supply pump pressure	1250	4.5 - 5.1 (kg/cm ²)	540 - 560	
1-3 Full load delivery	1250 (Full)	61.4 - 62.4 (cc/1000st)	540 - 560	4.5
Full load delivery	750 (BCS)	60.4 - 61.4 (cc/1000st)	320 - 340	
1-4 Idle speed regulation	375	8.5 - 11.5 (cc/1000st)	0	2.0
1-5 Start	100	43.0 - 83.0 (cc/1000st)	0	
1-6 Full-load speed regulation	2650	22.2 - 28.2 (cc/1000st)	540 - 560	5.5
1-7 Load-timer adjustment	1250	T = 0.4-0.8 (mm)	540 - 460	

2. Test values

2-1 Timing device	N = rpm mm	500 0.6-1.8	750 1.1-2.3	1250 3.4-4.0	2100 5.7-7.6
2-2 Supply pump	N = rpm kg/cm ²	600 2.9-3.5	1250 4.5 - 5.1	2100 6.5-7.1	
2-3 Overflow delivery	N = rpm cc/10s		1250 48 - 92		

2-4 Fuel injection quantities

Speed control lever pos.	Speed (rpm)	Fuel delivery (cc/1000st)	Charge-air pres (mmHg)	Difference in delivery (cc)
End stop	1250 (Full)	60.9 - 62.9	540 - 560	
	750 (BCS)	59.9 - 60.9	320 - 340	
	600	45.8 - 50.8	0	
	2100	54.1 - 59.1	540 - 560	
	2650	21.7 - 28.7	540 - 560	
	3050	below 5.0	540 - 560	
Switch off	375	0	0	
Idle-stop	750	below 3.0	0	
	375	8.5 - 11.5	0	

3. Dimensions

K	3.2 - 3.4 mm
KF	5.7 - 5.9 mm
MS	0.9 - 1.1 mm
BCS	- mm
Pre-str.	0.84 - 0.88 mm
Control lever angle	
α	55 - 63° deg
A	10.9 - 16.0 mm
β	36 - 46° deg
B	11.4 - 15.0 mm
γ	- deg
C	- mm

2-5 Solenoid Cut-in voltage max. 8 V Test voltage: 12 - 14 V

C1

ZEXEL - Test values
Injection pumps



C2

ZEXEL - Test values
Injection pumps



1. Adjustment

1) Fix the control lever in the position satisfying the following conditions:

Boost Pressure: 540 - 560 mmHg
 Pump Speed : 1250 rpm
 Fuel Injection Quantity: 49.5 - 50.5 cc/1000st

2) With the control lever positioned as described in 1) above, adjust the governor sleeve so that the Timer Stroke conforms to the specified values (page 1/3).

2. Confirmation of Timer Characteristics

Fix the control lever in the position satisfying the following conditions, and confirm the Timer Stroke.

Control lever position			Specified values	
Pump speed (rpm)	Fuel injection quantity (cc/1000st)	Boost pressure (mmHg)	Timer stroke (mm)	Timer stroke reduction value (mm)
1250	49.0 - 51.0	540 - 560	-	0.3 - 0.9
1250	38.5 - 41.5	540 - 560	-	0.9 - 1.9

C3

ZEXEL - Test values
 Injection pumps



C4

ZEXEL - Test values
 Injection pumps



■ FICD MOUNTING POSITION ADJUSTMENT

1. Hold the control lever in the idling position.
2. Position the FICD mounting bracket so that the gap between the control lever and the FICD lever is $1^{\pm 1}$ mm.

C5

ZEXEL - Test values

Injection pumps



Test oil
ISO 4113 or
SAE J967d

ZEXEL-TEST VALUES
Distributor pumps
Engine model: 4JB1-TC

1/4

BOSCH No.	9 460 610 453
ZEXEL No.	104741-5240
Date:	30.05.1991 [0]
Company:	ISUZU
No.	8970283300

Injection pump no.: 104641-5240 (NP-VE4/11F1900RNP773)

Pump rotation: clockwise viewed from
drive side

Test-nozzle holder combination:
1 688 901 022

Test pressure line:
1 680 750 073

1. Setting values	Speed (rpm)	Setting values	Charge-air pressure bar (mmHg)	Difference (cc)
1-1 Timing device travel	1500	4.9 - 5.3 (mm)	590 - 610	
1-2 Supply pump pressure	1500	4.7 - 5.1 (kg/cm ²)	590 - 610	
1-3 Full load delivery	1250 (Full)	64.7 - 65.7 (cc/1000st)	590 - 610	3.5
Full load delivery	800 (BCS)	45.3 - 46.3 (cc/1000st)	295 - 315	4.5
1-4 Idle speed regulation	385	6.1 - 10.1 (cc/1000st)	0	2.0
1-5 Start	100	80.0 - 90.0 (cc/1000st)	0	
1-6 Full-load speed regulation	2300	16.6 - 22.6 (cc/1000st)	590 - 610	4.5
1-7				

2. Test values

2-1 Timing device	Solenoid timer N = rpm mm	ON		OFF		
		385 below 1.2	750 above 1.0	1250 1.3-2.5	1500 4.8-5.4	1900 8.2-9.0
2-2 Supply pump	N = rpm kg/cm ²				1500 4.7-5.1	1900 5.8-6.4
2-3 Overflow delivery	N = rpm ⁻¹ cc/10s		1500 63-107		1500 78 - 168	

2-4 Fuel injection quantities

Speed control lever pos.	Speed (rpm)	Fuel delivery (cc/1000st)	Charge-air pres (mmHg)	Difference (cc)
End stop	1250 (Full)	64.2 - 66.2	590 - 610	
	800 (BCS)	44.8 - 46.8	295 - 315	
	400	33.4 - 46.4	0	
	600	31.8 - 39.8	130 - 150	
	1250	44.0 - 53.0		
	1900	62.0 - 73.0	590 - 610	
	2300	16.1 - 23.1	590 - 610	
	2400	below 12.0	590 - 610	
Switch off	385	0	0	
Idle-stop	500	below 3.0	0	
	385	6.1 - 10.1	0	
Partial load	750	7.7 - 9.7	590 - 610	

2-5 Solenoid
Cut-in voltage max.: 8 V
Test voltage: 12 - 14 V

3. Dimensions

K	2.7 - 2.9 mm
KF	5.4 - 5.6 mm
MS	0.9 - 1.1 mm
BCS	3.8 - 4.0 mm
Prestr.	0.43 - 0.47 mm

Control lever angle

α	20° - 28° deg
A	11.4 - 14.9 mm
β	43° - 53° deg
B	13.8 - 17.5 mm
γ	- deg
C	- mm

C6

ZEXEL - Test values
Injection pumps



C7

ZEXEL - Test values
Injection pumps



■ POTENTIOMETER ADJUSTMENT SPECIFICATIONS

Pump speed (rpm)	Out-put voltage (V)	Injection quantity mm ³ /st	Remarks
750	2.49 ± 0.03	8.7 ± 1 Boost = 600 mmHg	Adjustment point
385	0.96 ± 0.4	8.1 ± 2 (Idle)	Confirmation point

(In-put voltage: 10V)

1. At a pump speed of 750 rpm, hold the control lever in a position where a fuel injection quantity of 7.7 - 9.7 mm³/st can be obtained.
2. Screw in the adjusting screw until it contacts the control lever and fix it using the locknut.
3. Adjust the potentiometer so that the out-put voltage is 2.46 - 2.52 V.

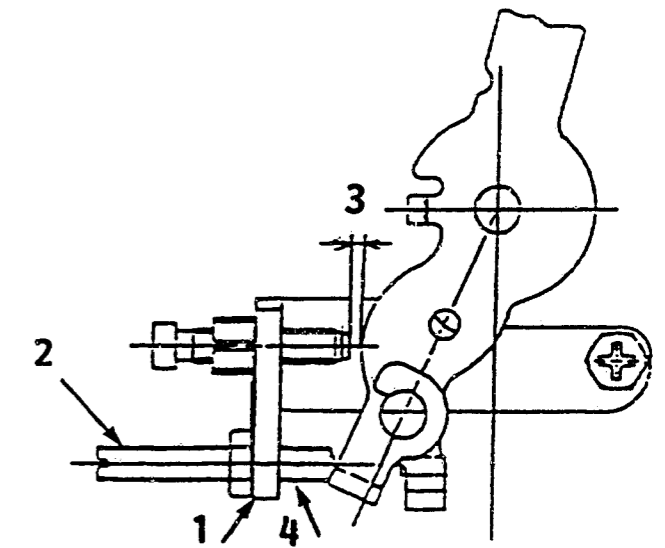

Fig. 17

- 1 = Adjusting screw
installation bracket
- 2 = Adjusting screw
- 3 = Shim (thickness)
- 4 = Adjusting screw and
locknut

C8

ZEXEL - Test values

Injection pumps



C9

ZEXEL - Test values

Injection pumps



Injection quantity specifications (Boost pressure = 600 mmHg)		Microswitch adjustment specifications	
Speed (rpm)	Injection quantity (mm ³ /st)	Microswitch operation	Potentiometer output (V)
1000	50.6 ± 3.5	ON → OFF	4.56 ± 0.05

1. Fix the adjusting screw used to adjust the potentiometer so that potentiometer output voltage is 4.56 V.
2. Move the microswitch in the direction of the arrow from the ON position to the OFF position, and fix it in this position.
3. Loosen the adjusting screw and confirm that potentiometer output voltage is 4.56 ± 0.05V when the microswitch moves from ON to OFF.

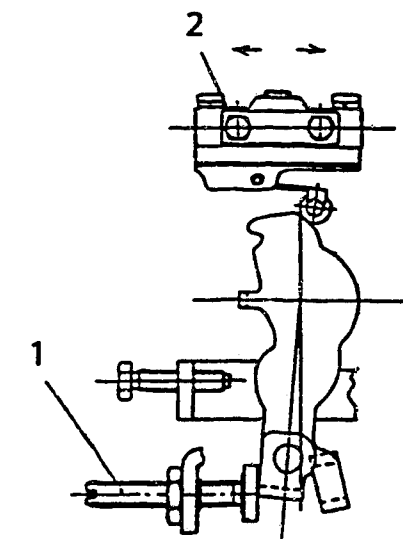

Figure 18

- 1 = Adjusting screw
- 2 = Microswitch fixing bolt
- T = 0.2 - 0.3 kgm



- Attach the timer's measuring device to the low pressure side.
- Adjust the pump with the magnet valve OFF.

■ V-FICD ADJUSTMENT

1. Adjust the bracket so that the clearance S is 1^{+1} mm.
2. Apply 400 mmHg negative pressure to the inside of the actuator and confirm that the actuator shaft moves the full stroke.

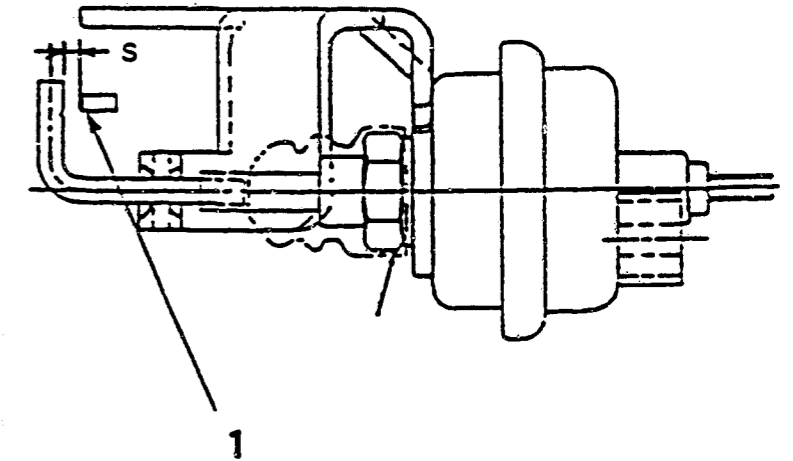

Figure 19

1 = Control lever (Idling position)

■ STARTING INJECTION QUANTITY ADJUSTMENT

Adjust the starting injection quantity (page 1/4) using the adjusting screw (as shown in the figure at right).

Figure 20

1 = Adjusting screw
2 = Locknut

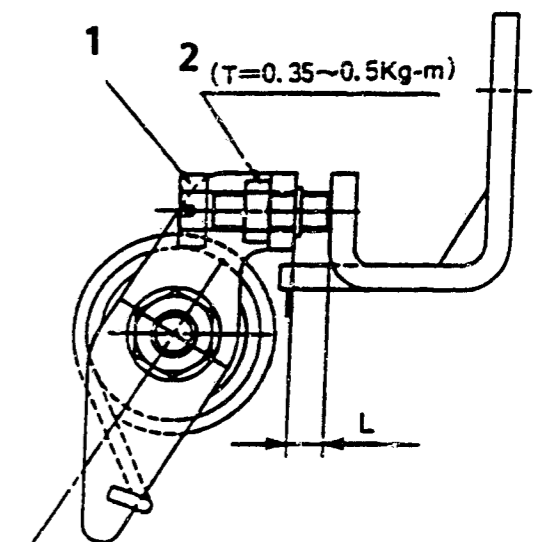

C12

ZEXEL - Test values
Injection pumps



C13

ZEXEL - Test values
Injection pumps



Test oil
ISO 4113 or
SAE J967d

ZEXEL - TEST VALUES
Distributor pumps
Engine model: 4EC1

1/2

BOSCH No. 9 460 610 475
ZEXEL No. 104748-1662
Date: 30.05.1991 [0]
Company: ISUZU
No. 8944088701

Injection pump no.: 104648-1322 (NP-VE4/8F2600RNP392)

Pump rot.: Clockwise-viewed from drive side Test-nozzle holder combination:
1 688 901 000

Test pressure line:
1 680 750 017

1. Setting values	Speed (rpm)	Setting values	Charge-air pressure bar (mmHg)	Difference in delivery (cc)
1-1 Timing device travel	1250	2.9 - 3.3 (mm)		
1-2 Supply pump pressure	1250	3.5 - 3.9 (kg/cm ²)		
1-3 Full load delivery	1250	28.0 - 29.0 (cc/1000st)		2.5
Full load delivery		- (cc/1000st)		
1-4 Idle speed regulation	375	4.4 - 8.4 (cc/1000st)		2.0
1-5 Start	100	above 50.0 (cc/1000st)		
1-6 Full-load speed regulation	2965	6.1 - 12.1 (cc/1000st)		3.5
1-7 Full-load delivery				

2. Test values						3. Dimensions	
2-1 Timing device	N = rpm	520 - 720	1250	2000	2300	K	3.2 - 3.4 mm
	mm	0.5	2.8-3.4	5.5-6.7	7.0-7.8	KF	5.7 - 5.9 mm
2-2 Supply pump	N = rpm	500	1250	2000	2300	MS	1.5 - 1.7 mm
	kg/cm ²	1.6-2.2	3.5-3.9	5.2-5.8	6.2-6.8	BCS	- mm
2-3 Overflow delivery	N = rpm		1250			Pre-st.	- mm
	cc/10s		40.0-83.0			Control lever angle	
2-4 Fuel injection quantities							
Speed control lever pos.	Speed (rpm)	Fuel delivery (cc/1000st)	Charge-air pres (mmHg)	Difference in delivery (cc)			
End stop	1250	27.5 - 29.5					
	600	25.1 - 29.1					
	2500	23.4 - 27.4					
	2600	23.4 - 27.4					
	2700	20.2 - 27.2					
	2900 *	below 2.5					
	2965	5.6 - 12.6					
Switch off	375	0					
Idle-stop	375	4.4 - 8.4					
	450	below 2.0					
2-5 Solenoid	Cut-in voltage max. 8 V Test voltage: 12 - 14 V						

C14

ZEXEL - Test values
Injection pumps



C15

ZEXEL - Test values
Injection pumps

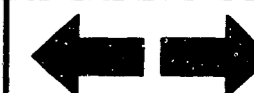

■ V-FICD ADJUSTMENT

1. Adjust the bracket so that the clearance S is 1^{+1} mm.
2. Apply 350 mmHg negative pressure to the inside of the actuator and confirm that the actuator shaft moves the full stroke.

■ For items marked *, confirmation is as follows:

- a) Insert the shims (3.8 ± 0.1 mm thick) between the control lever and the full-speed stopper bolt.
- b) Confirm the fuel injection quantity at the specified pump speed.



Test oil
ISO 4113 or
SAE J967d

ZEXEL-TEST VALUES
Distributor pumps
Engine model: 4EC1

1/4

BOSCH No. 9 460 610 481
ZEXEL No. 104748-1723
Date: 30.05.1991 [0]
Company: ISUZU
No. 8944685890

Injection pump no.:104648-1373

(NP-VE4/8F2600RNP284)

Pump rot.: Clockwise viewed from drive side

Test-nozzle holder combination:
1 688 901 000

Test pressure line:
1 680 750 017

1. Setting values		Speed (rpm)	Setting values	Charge-air pressure bar (mmHg)	Difference (cc)
1-1	Timing device travel	1250	2.7 - 3.1 (mm)		
1-2	Supply pump pressure	1250	3.5 - 3.9 (kg/cm ²)		
1-3	Full load delivery	1500	30.9 - 31.9 (cc/1000st)		2.5
	Full load delivery				
1-4	Idle speed regulation	400	7.6 - 11.6 (cc/1000st)		2.0
1-5	Start	100	45.0 - 65.0 (cc/1000st)		
1-6	Full-load speed regulation	2850	12.9 - 18.9 (cc/1000st)		3.5
1-7	Load-timer adjustment	1250	T= 0.6-1.0 (mm)		
1-8					

2. Test values

2-1 Timing device	N = rpm	1250	1500	2000	2300
	mm	2.6 - 3.2	3.7 - 4.7	5.5 - 5.7	7.0 - 7.8
2-2 Supply pump	N = rpm	500	1250	2000	2300
	kg/cm ²	1.6 - 2.2	3.4 - 4.0	5.2 - 5.8	6.0 - 6.6
2-3 Overflow delivery	N = rpm		1250		
	cc/10s		44.0 - 70.0		

2-4 Fuel injection quantities

Speed control lever pos.	Speed (rpm)	Fuel delivery (cc/1000st)	Charge-air pres (mmHg)	Difference (cc)
End stop	1500	30.4 - 32.4		2.5
	600	27.9 - 31.9		
	2000	28.2 - 32.1		
	2400	26.4 - 30.4		
	2600	25.5 - 29.7		3.5
	2850	12.4 - 19.4		
	2975	below 6.0		
Switch off	400	0		
Idle-stop	400	7.6 - 11.6		
	500	below 5.0		

2-5 Solenoid
Cut-in voltage max. 8 V
Test voltage: 12 - 14 V

3. Dimensions

K	3.2 - 3.4 mm
KF	5.7 - 5.9 mm
MS	1.3 - 1.5 mm
BCS	- mm
Pre-str.	- mm
Control lever angle	
α	16° - 24° deg
A	- mm
β	40° - 50° deg
B	- mm
γ	- deg
C	- mm

C17

ZEXEL - Test values
Injection pumps



C18

ZEXEL - Test values
Injection pumps



LOAD TIMER ADJUSTMENT

1. Adjustment

1) Fix the control lever in the position satisfying the following conditions:

Boost Pressure: - mmHg
 Pump Speed : 1250 rpm
 Fuel Injection Quantity: 17.5 - 18.5 cc/1000st

2) With the control lever positioned as described in 1) above, adjust the governor sleeve so that the Timer Stroke conforms to the specified values (1 - 7).

2. Confirmation of Timer Characteristics

Fix the control lever in the position satisfying the following conditions, and confirm the Timer Stroke.

Control lever position			Specified values	
Pump speed (rpm)	Fuel injection quantity (cc/1000st)	Boost pressure (mmHg)	Timer stroke (mm)	Timer stroke reduction value (mm)
1250	17.0 - 19.0	-	-	0.5 - 1.1
1250	5.5 - 8.5	-	-	1.7 - 2.7

C19

ZEXEL - Test values
 Injection pumps



C20

ZEXEL - Test values
 Injection pumps



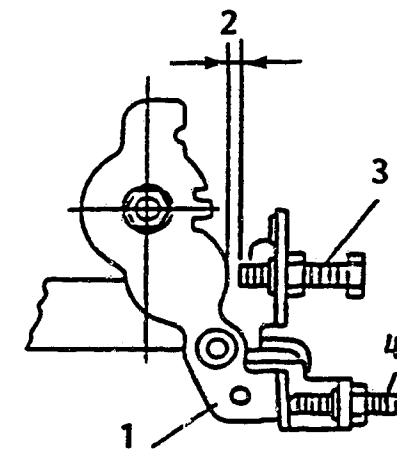
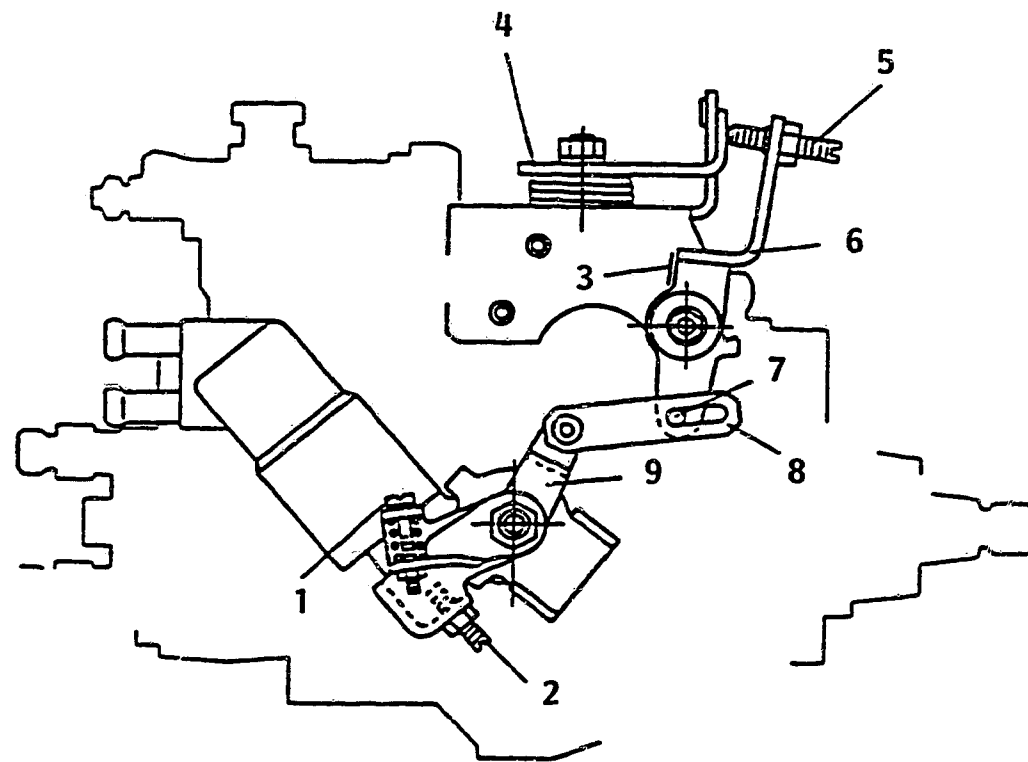

Figure 21

104747-1723 3/4

- 1 = Idling adjusting bolt
- 2 = Timer stroke adjusting screw
- 3 = Aligning mark
- 4 = Control lever

- 5 = Intermediate lever set screw
- 6 = Intermediate lever
- 7 = Pin
- 8 = Rod

- 1 = Control lever
- 2 = Intermediate lever set screw
- 3 = Idling stopper bolt
- 4 = Shim (l)

■ W-CSD ADJUSTMENT

1. Timer Stroke Adjustment (adjust to the thick line)

- 1) Calculate the timer stroke from Fig. 22 according to the atmospheric temperature at the time of adjustment.

C21

ZEXEL - Test values
Injection pumps



C22

ZEXEL - Test values
Injection pumps



(Continued)

2. Intermediate Lever Position Adjustment

- 1) Insert a block gauge (thickness gauge) of 1.2 ± 0.05 mm thickness between the control lever and the idling stopper bolt.
- 2) Align the intermediate lever with the aligning mark.
- 3) Adjust the intermediate lever set screw so that the control lever and the intermediate lever set screw are in contact, and then fix in position using the locknut.

C23

ZEXEL - Test values

Injection pumps



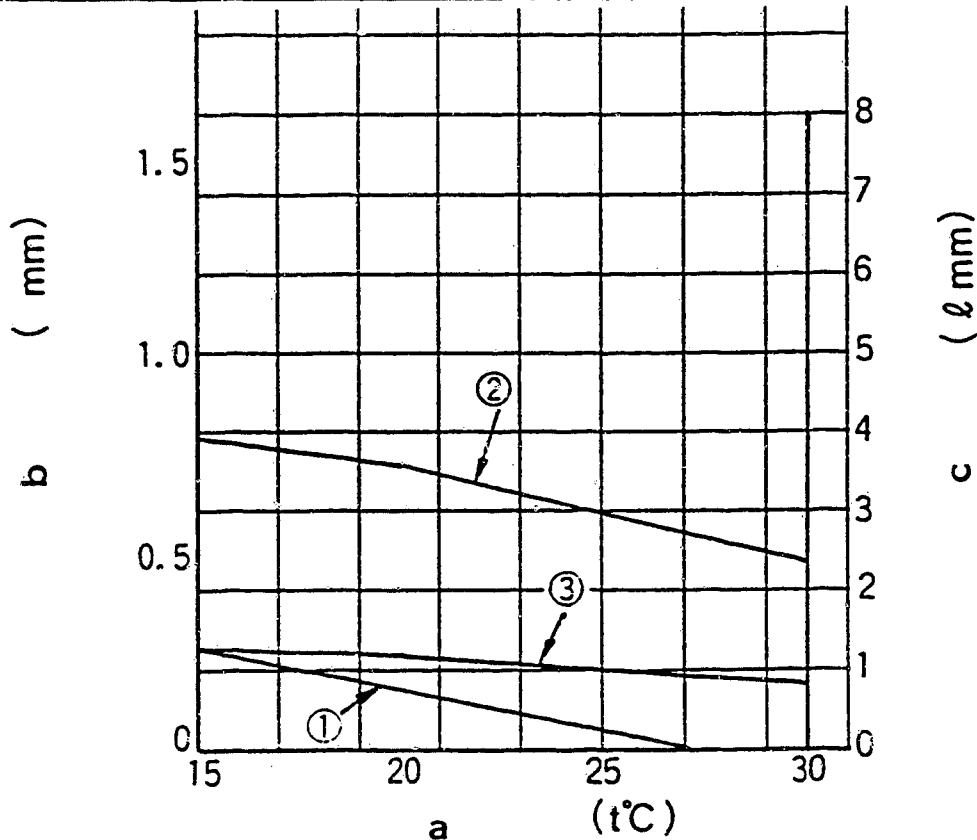

Figure 22

104748-1723 4/4

- a = Atmospheric temperature
- b = Timer stroke
- c = Gap between control lever and idling stopper bolt

3. CSD Lever Adjustment (adjust to the thick line)

- 1) Calculate the block gauge dimension $l \pm 0.05$ mm from Fig. 22 according to the atmospheric temperature at the time of adjustment.
- 2) Insert the block gauge (thickness gauge) between the control lever and the idling stopper bolt.
- 3) Using the idling bolt, adjust so that the CSD lever rod and the intermediate lever pin are in contact.



(Continued)

Timer Stroke (mm):

$$TA = -0.0215 t + 0.585$$

Control Lever Angle (deg):

$$Q_1 = -0.0625 t + 4.85 \quad (-20^\circ\text{C} \leq t \leq 20^\circ\text{C})$$

$$Q = -0.12 t + 6.0 \quad (20^\circ\text{C} < t \leq 50^\circ\text{C})$$

Clearance between Control Lever and Idling Stopper Bolt (mm):

$$l_1 = -0.02075 t + 1.585 \quad (-20^\circ\text{C} \leq t \leq 20^\circ\text{C})$$

$$l_2 = 0.039 t + 1.95 \quad (20^\circ\text{C} < t \leq 50^\circ\text{C})$$



Test oil:
ISO 4113 or
SAE J967d

ZEXEL - TEST VALUES
Distributors pumps
Engine model: CD17

1/2

BOSCH No. 9 460 610 482
ZEXEL No. 104748-2041
Date: 30.05.1991 [3]
Company: NISSAN
No. 16700 16A15

Injection pump no: 104648-2001 (NP-VE4/8F2500LNP134)

Pump rotation: Counter clockwise-viewed from drive side
Test-nozzle holder combination: 1 688 901 000

Test pressure line:
1 680 750 017

1. Setting values		Speed (rpm)	Setting values	Charge-air pressure bar (mmHg)	Difference (cc)	
1-1	Timing device travel	1200	1.8 - 2.4 (mm)		2.5	
1-2	Supply pump pressure	1200	3.1 - 3.7 (kg/cm ²)			
1-3	Full load delivery	1200	29.5 - 30.5 (cc/1000st)			
	Full load delivery		(cc/1000st)			
1-4	Idle speed regulation	400	8.3 - 11.3 (cc/1000st)			3.0
1-5	Start	100	50.0 - 70.0 (cc/1000st)			
1-6	Full-load speed regulation	2700	11.9 - 17.9 (cc/1000st)			
1-7	Load-timer adjustment					
1-8						

2. Test values

2-1 Timing device	N = rpm	1200	1800	2500
	mm	1.7 - 2.5	4.0 - 5.2	6.8 - 8.0
2-2 Supply pump	N = rpm	1200	1800	2500
	kg/cm ²	3.0 - 3.8	4.4 - 5.2	6.1 - 6.9
2-3 Overflow delivery	N = rpm	1200		
	cc/10s	36.0 - 80.0		

2-4 Fuel injection quantities

Control lever position	Speed rpm	Fuel delivery (cc/1000 strokes)	Charge-air pres (mmHg)	Difference (cc)
End stop	1200	29.0 - 31.0		
	600	24.8 - 28.8		
	2500	26.7 - 30.7		
	2700	11.4 - 18.4		
	2900	below 6.0		
Switch off	400	0		
Idle stop	400	7.8 - 11.8		
	600	below 3.0		
Partial load	700	13.3 - 20.0		

2-5 Solenoid
Cut-in voltage max. 8 V
Test voltage: 12 - 14 V

3. Dimensions

K	3.2 - 3.4 mm
KF	5.7 - 5.9 mm
MS	1.7 - 1.9 mm
BCS	- mm
Pre-st.	- mm

Control lever angle

α	21° - 29° deg
A	2.5 - 8.0 mm
β	37° - 47° deg
B	10.7 - 14.8 mm
γ	10.5 - 11.5 deg
C	6.7 - 7.3 mm

C26

ZEXEL - Test values
Injection pumps



C27

ZEXEL - Test values
Injection pumps



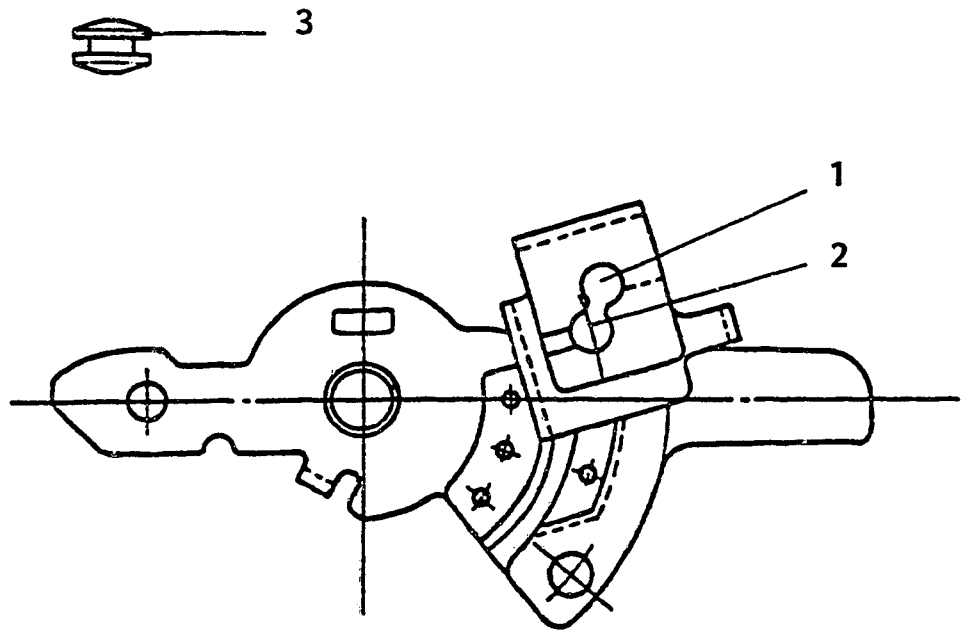

104748-2041 2/2

Figure 23

- 1 = Position A
- 2 = Position B
- 3 = Plug

■ Plug Positions

The plug's installation position (shown above) depends on the value of control lever angle β .

Position A: When 37° (10.7 mm) $\leq \beta < 41^\circ$ (12.4 mm)

Position B: When 41° (12.4 mm) $\leq \beta \leq 47^\circ$ (14.8 mm)



Test oil:
ISO 4113 or
SAE J967d

ZEXEL - TEST VALUES
Distributors pumps
Engine model: CD17

BOSCH No.	9 460 610 483
ZEXEL No.	104748-2100
Date:	30.05.1991 [3]
Company:	NISSAN
No.	16700 16A01

Injection pump no: 104648-2070

(NP-VE4/8F2500LNP134)

Pump rotation: Counter clockwise-viewed from drive side
Test-nozzle holder combination:
1 688 901 000

Test pressure line:
1 680 750 017

1. Setting values		Speed (rpm)	Setting values	Charge-air pressure bar (mmHg)	Difference (cc)
1-1	Timing device travel	1200	1.8 - 2.4 (mm)		
1-2	Supply pump pressure	1200	3.1 - 3.7 (kg/cm ²)		
1-3	Full load delivery	1200	29.5 - 30.5 (cc/1000st)		2.5
	Full load delivery		(cc/1000st)		
1-4	Idle speed regulation	400	5.3 - 8.3 (cc/1000st)		3.0
1-5	Start	100	50.0 - 70.0 (cc/1000st)		
1-6	Full-load speed regulation	2700	11.9 - 17.9 (cc/1000st)		
1-7	Load-timer adjustment				
1-8					

2. Test values

2-1 Timing device	N = rpm mm	1200 1.7 - 2.5	1800 4.0 - 5.2	2500 6.8 - 8.0
2-2 Supply pump	N = rpm kg/cm ²	1200 3.0 - 3.8	1800 4.4 - 5.2	2500 6.1 - 6.9
2-3 Overflow delivery	N = rpm cc/10s	1200 36.0 - 80.0		

2-4 Fuel injection quantities

Control lever position	Speed rpm	Fuel delivery (cc/1000 strokes)	Charge-air pres (mmHg)	Difference (cc)
End stop	1200	29.0 - 31.0		
	600	24.8 - 28.8		
	2500	26.7 - 30.7		
	2700	11.4 - 18.4		
	2900	below 6.0		
Switch off	400	0		
Idle stop	400	4.8 - 8.8		
	600	below 3.0		
Partial load	700	10.0 - 20.0		

2-5 Solenoid
Cut-in voltage max. 8 V
Test voltage: 12 - 14 V

3. Dimensions

K	3.2 - 3.4 mm
KF	5.7 - 5.9 mm
MS	1.7 - 1.9 mm
BCS	- mm
Pre-st.	- mm

Control lever angle

α	21° - 29° deg
A	2.5 - 8.0 mm
β	39° - 49° deg
B	11.0 - 16.0 mm
γ	13.5 - 14.5 deg
C	8.6 - 9.2 mm

D1

ZEXEL - Test values
Injection pumps



D2

ZEXEL - Test values
Injection pumps



Test oil:
ISO 4113 or
SAE J967d

ZEXEL - TEST VALUES
Distributors pumps
Engine model: CD17

1/2

BOSCH No.	9 460 610 484
ZEXEL No.	104748-2110
Date:	30.05.1991 [0]
Company:	NISSAN
No.	16700 16A06

Injection pump no: 104648-2070

(NP-VE4/8F2500LNP134)

Pump rotation: Counter clockwise-viewed from drive side
Test-nozzle holder combination:
1 688 901 000

Test pressure line:
1 680 750 017

1. Setting values	Speed (rpm)	Setting values	Charge-air pressure bar (mmHg)	Difference (cc)
1-1 Timing device travel	1200	1.8 - 2.4 (mm)		
1-2 Supply pump pressure	1200	3.1 - 3.7 (kg/cm ²)		
1-3 Full load delivery	1200	29.5 - 30.5 (cc/1000st)		2.5
Full load delivery		(cc/1000st)		
1-4 Idle speed regulation	400	8.3 - 11.3 (cc/1000st)		3.0
1-5 Start	100	50.0 - 70.0 (cc/1000st)		
1-6 Full-load speed regulation	2700	11.9 - 17.9 (cc/1000st)		
1-7 Load-timer adjustment				
1-8				

2. Test values

2-1 Timing device	N = rpm mm	1200 1.7 - 2.5	1800 4.0 - 5.2	2500 6.8 - 8.0
2-2 Supply pump	N = rpm kg/cm ²	1200 3.0 - 3.8	1800 4.4 - 5.2	2500 6.1 - 6.9
2-3 Overflow delivery	N = rpm cc/10s	1200 36.0 - 80.0		

2-4 Fuel injection quantities

Control lever position	Speed rpm	Fuel delivery (cc/1000 strokes)	Charge-air pres (mmHg)	Difference (cc)
End stop	1200	29.0 - 31.0		
	600	24.8 - 28.8		
	2500	26.7 - 30.7		
	2700	11.4 - 18.4		
	2900	below 6.0		
Switch off	400	0		
Idle stop	400	7.8 - 11.8		
	600	below 3.0		
Partial load	700	13.3 - 20.0		
2-5 Solenoid	Cut-in voltage max. 8 V Test voltage: 12 - 14 V			

3. Dimensions

K	3.2 - 3.4 mm
KF	5.7 - 5.9 mm
MS	1.7 - 1.9 mm
BCS	- mm
Pre-st.	- mm
Control lever angle	
α	21° - 29° deg
A	2.5 - 8.0 mm
β	37° - 47° deg
B	10.7 - 14.8 mm
γ	10.5 - 11.5 deg
C	6.7 - 7.3 mm

D3

ZEXEL - Test values
Injection pumps



D4

ZEXEL - Test values
Injection pumps



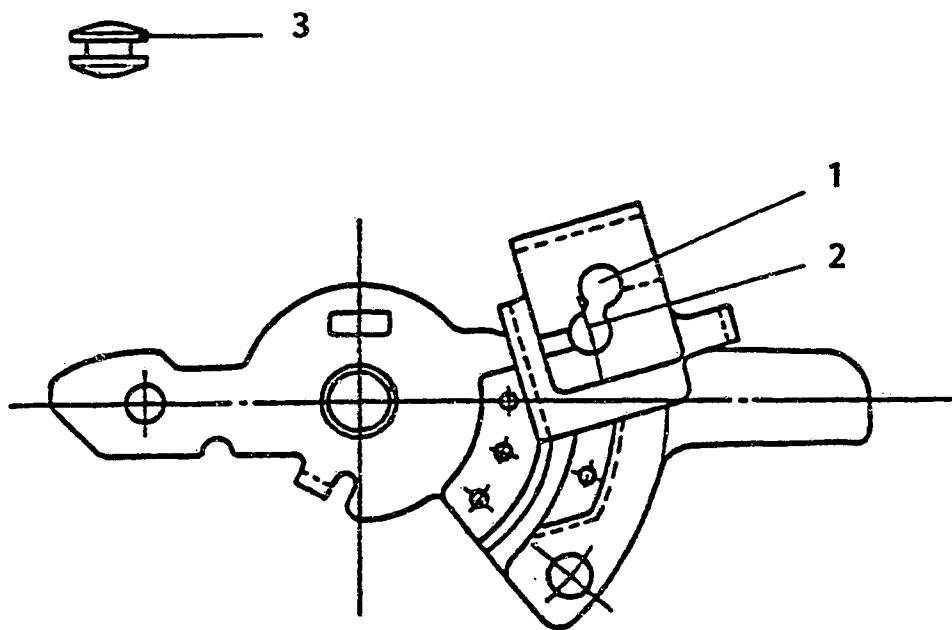

104748-2110 2/2

Figure 24

- 1 = Position A
- 2 = Position B
- 3 = Plug

■ Plug Positions

The plug's installation position (shown above) depends on the value of control lever angle β .

Position A: When 37° (10.7 mm) $\leq \beta < 41^\circ$ (12.4 mm)

Position B: When 41° (12.4 mm) $\leq \beta \leq 47^\circ$ (14.8 mm)

D5

ZEXEL - Test values

Injection pumps



Test oil:
ISO 4113 or
SAE J967d

ZEXEL - TEST VALUES
Distributors pumps
Engine model: CD17

BOSCH No.	9 460 610 485
ZEXEL No.	104748-2332
Date:	30.05.1991 [0]
Company:	NISSAN
No.	16700 16A03

Injection pump no: 104648-2172 (NP-VE4/8F2500LNP134)

Pump rotation: Counter clockwise-viewed from drive side
Test-nozzle holder combination: 1 688 901 000
Test pressure line: 1 680 750 017

1. Setting values	Speed (rpm)	Setting values	Charge-air pressure bar (mmHg)	Difference (cc)
1-1 Timing device travel	1200	1.8 - 2.4 (mm)		2.5
1-2 Supply pump pressure	1200	3.1 - 3.7 (kg/cm ²)		
1-3 Full load delivery	1200	29.5 - 30.5 (cc/1000st)		
Full load delivery		(cc/1000st)		
1-4 Idle speed regulation	400	5.3 - 8.3 (cc/1000st)		
1-5 Start	100	50.0 - 70.0 (cc/1000st)		
1-6 Full-load speed regulation	2700	11.9 - 17.9 (cc/1000st)		
1-7 Load-timer adjustment				
1-8				

2. Test values

2-1 Timing device	N = rpm mm	1200 1.7 - 2.5	1800 4.0 - 5.2	2500 6.8 - 8.0
2-2 Supply pump	N = rpm kg/cm ²	1200 3.0 - 3.8	1800 4.4 - 5.2	2500 6.1 - 6.9
2-3 Overflow delivery	N = rpm cc/10s	1200 36.0 - 38.0		

2-4 Fuel injection quantities

Control lever position	Speed rpm	Fuel delivery (cc/1000 strokes)	Charge-air pres (mmHg)	Difference (cc)
End stop	1200	29.0 - 31.0		2.5
	600	24.8 - 28.8		
	2500	26.7 - 30.7		
	2700	11.4 - 18.4		
	2900	below 6.0		
Switch off	400	0		
Idle stop	400	4.8 - 8.8		
	600	below 3.0		
Partial load	700	10.0 - 20.0		
2-5 Solenoid	Cut-in voltage max. 8 V Test voltage: 12 V			

3. Dimensions

K	3.2 - 3.4 mm
KF	5.7 - 5.9 mm
MS	1.5 - 1.7 mm
BCS	- mm
Pre-st.	- mm
Control lever angle	
α	1.0 - -1.0 deg
A	15.4 - 18.1 mm
β	39.0 - 49.0 deg
B	11.0 - 16.0 mm
γ	13.5 - 14.5 deg
C	8.6 - 9.2 mm

D6

ZEXEL - Test values
Injection pumps



D7

ZEXEL - Test values
Injection pumps



Test oil:
ISO 4113 or
SAE J967d

ZEXEL - TEST VALUES
Distributors pumps
Engine model: CD17

1/2

BOSCH No.	9 460 610 486
ZEXEL No.	104748-2342
Date:	30.05.1991 [0]
Company:	NISSAN
No.	16700 16A08

Injection pump no: 104648-2172 (NP-VE4/8F2500LNP134)

Pump rotation: Counter clockwise-viewed from drive side
Test-nozzle holder combination: 1 688 901 000
Test pressure line: 1 680 750 017

1. Setting values		Speed (rpm)	Setting values	Charge-air pressure bar (mmHg)	Difference (cc)
1-1	Timing device travel	1200	1.8 - 2.4 (mm)		2.5
1-2	Supply pump pressure	1200	3.1 - 3.7 (kg/cm ²)		
1-3	Full load delivery	1200	29.5 - 30.5 (cc/1000st)		
	Full load delivery		(cc/1000st)		
1-4	Idle speed regulation	400	8.3 - 11.3 (cc/1000st)		
1-5	Start	100	50.0 - 70.0 (cc/1000st)		
1-6	Full-load speed regulation	2700	11.9 - 17.9 (cc/1000st)		
1-7	Load-timer adjustment				
1-8					

2. Test values				
2-1 Timing device	N = rpm	1200	1800	2500
	mm	1.7 - 2.5	4.0 - 5.2	6.8 - 8.0
2-2 Supply pump	N = rpm	1200	1800	2500
	kg/cm ²	3.0 - 3.8	4.4 - 5.2	6.1 - 6.9
2-3 Overflow delivery	N = rpm	1200		
	cc/10s	36.0 - 80.0		
2-4 Fuel injection quantities				
Control lever position	Speed rpm	Fuel delivery (cc/1000 strokes)	Charge-air pres(mmHg)	Difference (cc)
End stop	1200	29.0 - 31.0		
	600	24.8 - 28.8		
	2500	26.7 - 30.7		
	2700	11.4 - 18.4		
	2900	below 6.0		
Switch off	400	0		
Idle stop	400	7.8 - 11.8		2.5
	600	below 3.0		
Partial load	700	13.3 - 20.0		
2-5 Solenoid	Cut-in voltage max. 8 V Test voltage: 12 - 14 V			

3. Dimensions	
K	3.2 - 3.4 mm
KF	5.7 - 5.9 mm
MS	1.5 - 1.7 mm
BCS	- mm
Pre-st.	- mm
Control lever angle	
α	1.0 - -1.0 deg
A	15.4 - 18.1 mm
β	37.0 - 47.0 deg
B	10.7 - 14.8 mm
γ	10.5 - 11.5 deg
C	6.7 - 7.3 mm

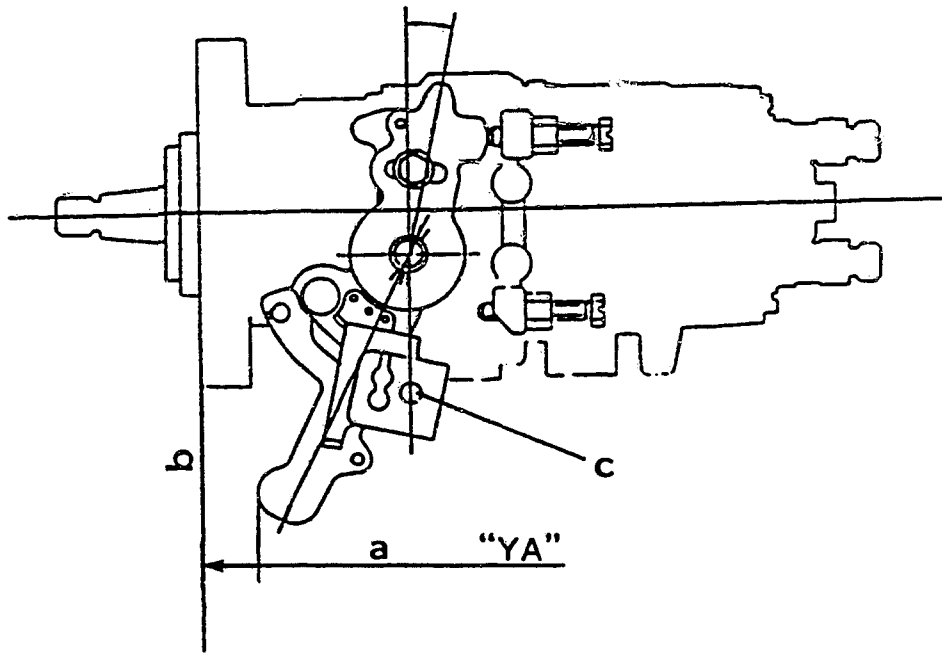

Figure 25

104748-2342 2/2

a = Dimension

b = End face of flange

c = Hole "A"

■ CONTROL LEVER ANGLE MEASUREMENT POSITION

1. Measure the control lever angles (α , β , γ) at hole "A".

2. Marking Positions

The control lever is marked (painted) at the positions (shown below), depending on the value of control lever angle β .

Position "a": \Rightarrow $\beta \leq 39.5^\circ$ (B = 11.7 mm)

Position "b": \Rightarrow 39.5° (B = 11.7 mm)

$< \beta \leq 42.5^\circ$ (B = 13.0 mm)

Position "c": \Rightarrow $\beta > 42.5^\circ$ (B = 13.0 mm)

D10

ZEXEL - Test values

Injection pumps



Test oil: ISO 4113 or SAE J967d	ZEXEL - TEST VALUES Distributors pumps Engine model: 4FD1	BOSCH No. 9 460 610 476 ZEXEL No. 104749-6470 Date: 30.05.1991 [0] Company: ISUZU No. 8944185260
Injection pump no: 104649-1720	(NP-VE4/9F2250RNP373)	

Pump rotation: Clockwise-viewed from drive side	Test-nozzle holder combination: 1 688 901 000	Test pressure line: 1 680 750 017
---	--	--------------------------------------

1. Setting values	Speed (rpm)	Setting values	Charge-air pressure bar (mmHg)	Difference (cc)
1-1 Timing device travel	1250	3.4 - 3.8 (mm)		
1-2 Supply pump pressure	1250	4.6 - 5.0 (kg/cm ²)		
1-3 Full load delivery	1250	35.3 - 36.3 (cc/1000st)		3.0
1-4 Idle speed regulation	340	5.6 - 9.6 (cc/1000st)		2.0
1-5 Start	100	50.0 - 70.0 (cc/1000st)		
1-6 Full-load speed regulation	2600	13.1 - 19.1 (cc/1000st)		4.5
1-7 Load-timer adjustment				
1-8				

2. Test values

2-1 Timing device	N = rpm	1250	2000	2500
	mm	3.3 - 3.9	6.3 - 7.5	8.6 - 9.4
2-2 Supply pump	N = rpm	1250	2000	2500
	kg/cm ²	4.6 - 5.0	6.2 - 6.8	7.6 - 8.2
2-3 Overflow delivery	N = rpm	1250		
	cc/10s	55.0 - 98.0		

2-4 Fuel injection quantities

Control lever position	Speed rpm	Fuel delivery (cc/1000 strokes)	Charge-air pres (mmHg)	Difference (cc)
End stop	1250	34.8 - 36.8		
	600	28.8 - 32.8		
	2250	31.2 - 35.4		
	2600	12.6 - 19.6		
	2900	below 4.5		
Switch off	340	0		
Idle stop	340	5.6 - 9.6		
	450	0		

2-5 Solenoid Cut-in voltage max. 8 V
Test voltage: 12 - 14 V

3. Dimensions

K	3.2 - 3.4	mm
KF	5.7 - 5.9	mm
MS	1.5 - 1.7	mm
BCS	-	mm
Pre-st.	-	mm

Control lever angle

α	-2.0 - 6.0	deg
A	8.5 - 11.1	mm
β	40.0 - 50.0	deg
B	12.8 - 16.1	mm
γ	-	deg
C	-	mm

Test oil:
ISO 4113 or
SAE J967d

ZEXEL - TEST VALUES
Distributors pumps
Engine model: LD28

1/4

BOSCH No.	9 460 610 497
ZEXEL No.	104769-2074
Date:	30.05.1991 [0]
Company:	NISSAN
No.	16700 50L15

Injection pump no: 104669-2132 (NP-VE6/9F2500RNP34)

Pump rotation: Clockwise-viewed from drive side
Test-nozzle holder combination: 1 688 901 000
Test pressure line: 1 680 750 017

1. Setting values	Speed (rpm)	Setting values	Charge-air pressure bar (mmHg)	Difference (cc)
1-1 Timing device travel	900	2.0 - 2.6 (mm)		2.5
1-2 Supply pump pressure	900	3.5 - 4.1 (kg/cm ²)		
1-3 Full load delivery	900	29.0 - 30.0 (cc/1000st)		
Full load delivery		(cc/1000st)		
1-4 Idle speed regulation	350	6.3 - 9.3 (cc/1000st)		
1-5 Start	100	40.8 - 48.8 (cc/1000st)		
1-6 Full-load speed regulation	2600	15.5 - 21.5 (cc/1000st)		
1-7 Load-timer adjustment	900	T = 0.2-0.8 (mm)		
1-8				

2. Test values

2-1 Timing device	N = rpm mm	900 1.9 - 2.7	1200 3.5 - 4.7	2300 8.1 - 9.0
2-2 Supply pump	N = rpm kg/cm ²	900 3.4 - 4.2	1800 5.5 - 6.3	2500 7.2 - 8.0
2-3 Overflow delivery	N = rpm cc/10s	900 43.0 - 87.0		

2-4 Fuel injection quantities

Control lever position	Speed rpm	Fuel delivery (cc/1000 strokes)	Charge-air pres (mmHg)	Difference (cc)
End stop	900	28.5 - 30.5		2.2
	600	27.0 - 31.0		
	2300	28.8 - 32.8		
	2600	15.0 - 22.0		
	2800	below 5.0		
Switch off	350	0		
Idle stop	350	5.8 - 9.8		
	500	below 4.0		
Partial load	900	2.1 - 12.1		

2-5 Solenoid
Cut-in voltage max. 8 V
Test voltage: 12 - 14 V

3. Dimensions

K	3.2 - 3.4 mm
KF	6.54 - 6.74 mm
MS	1.7 - 1.9 mm
BCS	- mm
Pre-st.	- mm

Control lever angle

α	21° - 29° deg
A	5.7 - 9.5 mm
β	39° - 49° deg
B	11.0 - 16.0 mm
γ	10.5 - 11.5 deg
C	4.8 - 5.2 mm

D13

ZEXEL - Test values
Injection pumps



D14

ZEXEL - Test values
Injection pumps

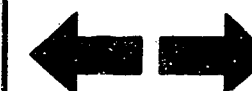

STARTING INJECTION QUANTITY ADJUSTMENT

Adjust the starting injection quantity (page 1/4) using the adjusting bolt (as shown in the figure at right).

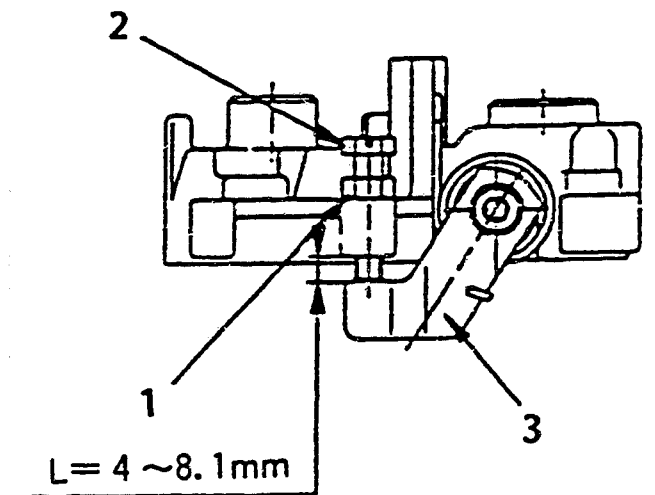

Figure 26

1 = Locknut
2 = Adjusting bolt
3 = Stop lever

LOAD TIMER ADJUSTMENT

1. Adjustment

1) Fix the control lever in the position satisfying the following conditions:

Boost Pressure:	-	mmHg
Pump Speed :	900	rpm
Fuel Injection Quantity:	8.0 - 10.0	cc/1000st

2) With the control lever positioned as described in 1) above, adjust the governor sleeve so that the Timer Stroke conforms to the specified values (page 1/4).

D15

ZEXEL - Test values
Injection pumps



D16

ZEXEL - Test values
Injection pumps



W-CSD ADJUSTMENT

1. Timer Stroke Adjustment (adjust to the thick line)

- 1) Calculate the timer stroke from Fig. 29 (diagram) according to the atmospheric temperature at the time of adjustment.
- 2) Adjust using the timer stroke adjusting screw (1) so that the timer stroke is as calculated in item 1.

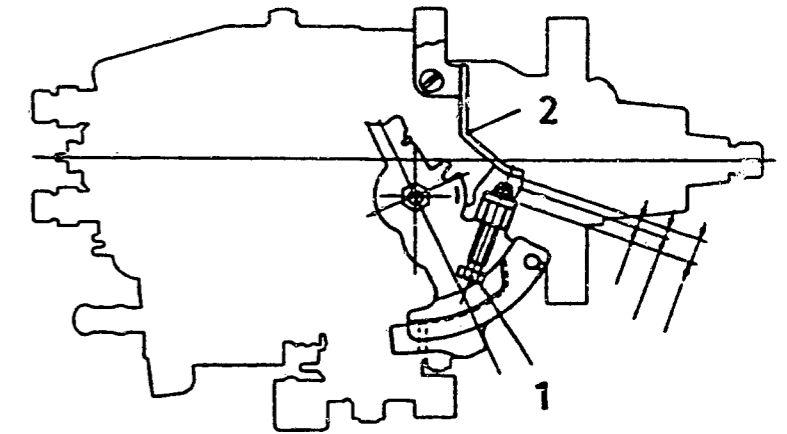

Figure 27

- 1 = Idling stopper bolt
- 2 = Bracket

2. Intermediate Lever Position Adjustment

- 1) Insert a block gauge (thickness gauge) of 0.9 ± 0.05 mm thickness between the control lever and the idling stopper bolt.
- 2) Align the intermediate lever with the aligning mark.
- 3) Adjust the intermediate lever set screw so that the control lever and the intermediate lever set screw are in contact, and then fix in position using the locknut.

Figure 28

- 1 = Timer stroke adjusting screw
- 2 = Idling adjusting bolt
- 3 = Aligning mark
- 4 = Control lever
- 5 = Intermediate lever set screw
- 6 = Intermediate lever
- 7 = CSD lever

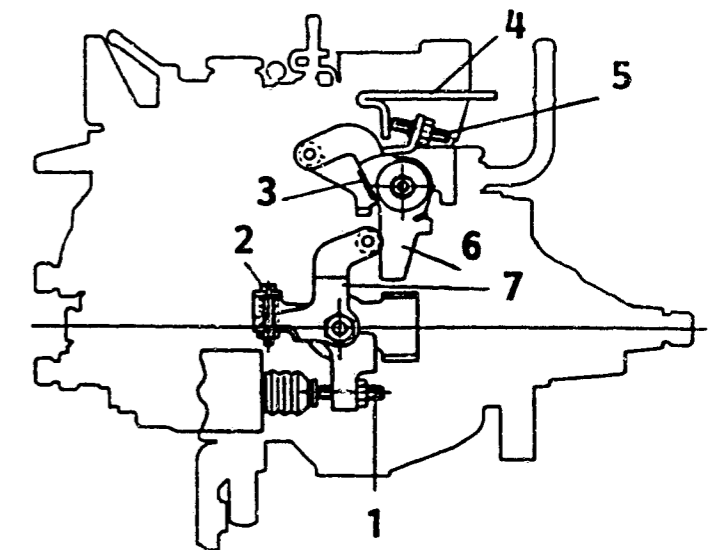

D17

ZEXEL - Test values
Injection pumps



D18

ZEXEL - Test values
Injection pumps



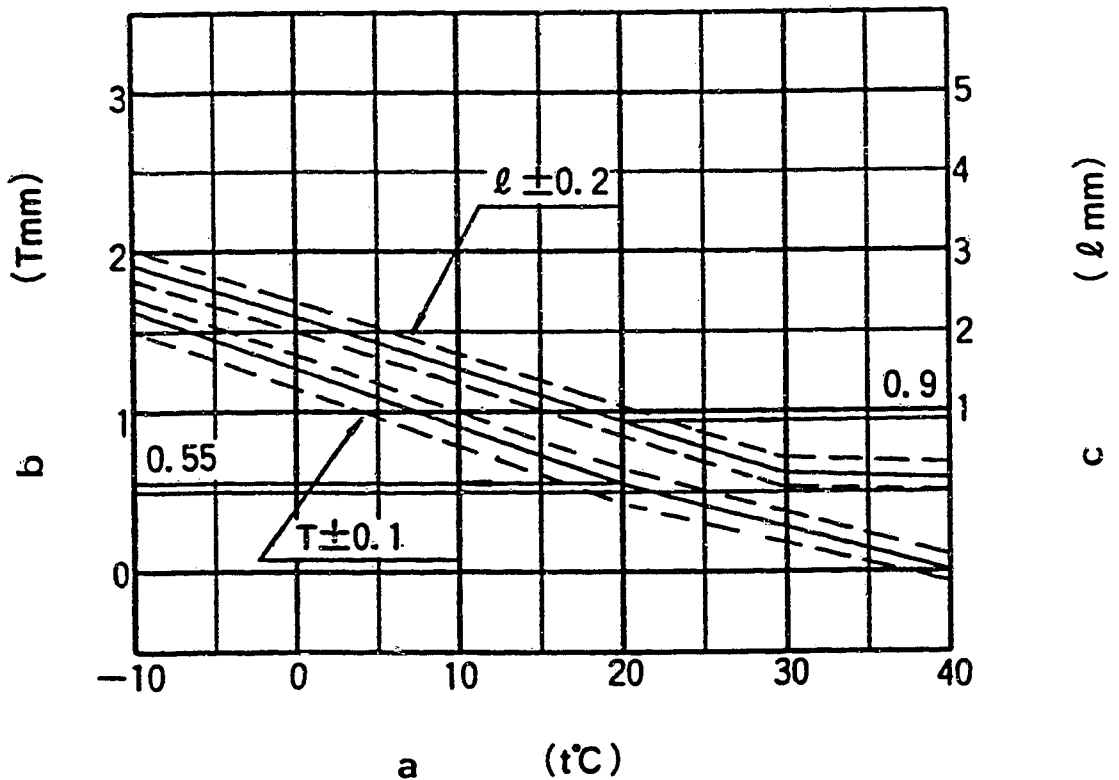

104769-2074 4/4

Figure 29

- a = Atmospheric temperature
- b = Timer stroke
- c = Gap between control lever and idling stopper bolt

3. CSD Lever Adjustment (adjust to the thick line)

- 1) Calculate the block gauge dimension $l \pm 0.05$ mm from (Fig. 29) according to the atmospheric temperature at the time of adjustment.
- 2) Insert the block gauge (thickness gauge) between the control lever and the idling stopper bolt.
- 3) Using the idling bolt, adjust so that the CSD lever roller and the intermediate lever are in contact.



(Continued)

4. Final adjustment

After completing the adjustment, screw the timer stroke adjusting screw two turns clockwise.
(Move from the temporary adjustment chart to the final adjustment chart).

* This W-CSD's timer stroke operations are effective at atmospheric temperatures of 30°C or above. Therefore, to make adjustment at normal temperatures possible, after adjusting to the substitute characteristics, tighten the timer stroke adjusting screw two turns.

Note:

1. The temperature of the wax must be below 30°C when adjusting.
2. When inserting a block gauge (thickness gauge) between the control lever (bracket) and the idling stopper bolt, use the idling adjusting bolt to separate the CSD lever and the intermediate lever so that no excessive force is exerted on them.

$-10 \leq \theta \text{ (}^\circ\text{C)} \leq 20$	$TA = -0.0367 \theta + 1.284$	$-10 \leq \theta \text{ (}^\circ\text{C)} \leq 20$	$l = -0.0628 \theta + 2.1555$
$20 \leq \theta \text{ (}^\circ\text{C)} \leq 40$	$TA = -0.0275 \theta + 1.1$	$20 \leq \theta \text{ (}^\circ\text{C)} \leq 30$	$l = -0.0507 \theta + 1.9142$
		$30 \leq \theta \text{ (}^\circ\text{C)} \leq 50$	$l = -0.0196 \theta + 0.9809$

D20

ZEXEL - Test values
Injection pumps

**D21**

ZEXEL - Test values
Injection pumps



Test oil
ISO 4113 or
SAE J967d

ZEXEL - TEST VALUES
Distributor pumps
Engine model: RD28-T

BOSCH No. 9 460 610 488
ZEXEL No. 104769-2162
Date: 30.05.1991 [0]
Company: NISSAN
No. 16700 22J10

Injection pump no.: 104669-2162

(NP-VE6/9F2300RNP58)

Pump rot.: Clockwise-viewed from drive side

Test-nozzle holder combination:
1 688 901 000

Test pressure line:
1 680 750 017

1. Setting values		Speed (rpm)	Setting values	Charge-air pressure bar (mmHg)	Difference (cc)
1-1	Timing device travel	900	1.1 - 1.5 (mm)	342 - 362	
1-2	Supply pump pressure	900	3.5 - 4.1 (kg/cm ²)	342 - 362	
1-3	Full load delivery	600	31.3 - 32.1 (cc/1000st)	0	2.0
	Full load delivery	900	38.6 - 39.4 (cc/1000st)	240 - 260	2.0
1-4	Idle speed regulation	350	6.6 - 8.6 (cc/1000st)	0	0.9
1-5	Start	100	above 38.0 (cc/1000st)	0	
1-6	Full-load speed regulation	2350	35.3 - 37.3 (cc/1000st)	470 - 490	4.5
1-7	Load-timer adjustment				

2. Test values

2-1 Timing device	N = rpm mm	900 1.1-1.5	1800 4.3-5.4	2300 6.3-7.4	2500 6.5-7.4
2-2 Supply pump	N = rpm kg/cm ²	900 3.5-4.1	1800 5.6-6.2	2300 6.9-7.5	
2-3 Overflow delivery	N = rpm cc/10s	900 43.0-87.0			

2-4 Fuel injection quantities

Speed control lever pos.	Speed (rpm)	Fuel delivery (cc/1000st)	Charge-air pres (mmHg)	Difference (cc)
End stop	900	38.1 - 39.9	240 - 260	
	600	30.8 - 32.6	0	
	1200	42.0 - 46.0	470 - 490	
	1800	41.2 - 45.2	470 - 490	
	2200	40.5 - 46.5	470 - 490	
	2300	37.8 - 44.8	470 - 490	
	2350	34.8 - 37.8	470 - 490	
	2500	14.0 - 24.0	470 - 490	
Switch off	2800	below 3.0	470 - 490	
	350	0	0	
Idle-stop	900	0	342 - 362	
	350	6.6 - 8.6	0	
Partial load	500	below 3.0	0	
	900	6.6 - 12.6	0	

2-5 Solenoid
Cut-in voltage max. 8 V
Test voltage: 12 - 14 V

3. Dimensions

K 3.2 - 3.4 mm
KF 6.54 - 6.74 mm
MS 1.7 - 1.9 mm
BCS 3.8 - 4.0 mm
Pre-st. - mm

Control lever angle

α 19 - 27° deg
A 8.7 - 12.9 mm
 β 37 - 47° deg
B 11.5 - 15.2 mm
 γ 10.5 - 11.5° deg
C 5.7 - 6.3 mm

E1

ZEXEL - Test values
Injection pumps



E2

ZEXEL - Test values
Injection pumps



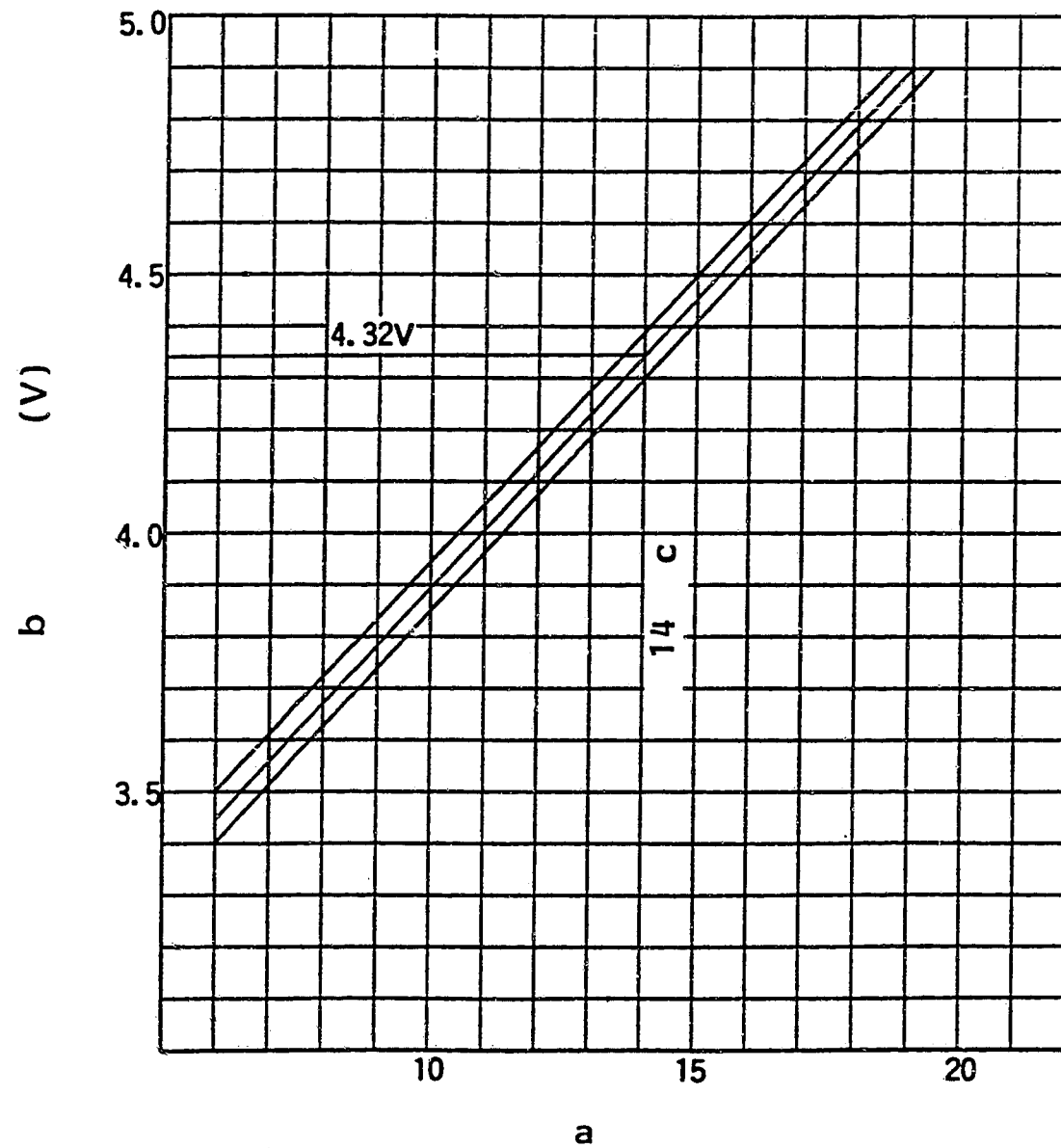

■ POTENTIOMETER ADJUSTMENT

Fig. 30

104769-2162 2/4

a = Fuel injection quantity (cm³/1000st)
 b = Out-put voltage
 c = cm³/1000st

E3

ZEXEL - Test values
 Injection pumps



E4

ZEXEL - Test values
 Injection pumps



Under the following conditions, alter the potentiometer's installation position so that the out-put voltage equals the specified value.

Adjustment Conditions			Specified Value	Remarks
Control lever position	Pump speed (rpm)	Fuel injection quantity (cc/1000st)	Out-put voltage (V)	
(Approx. 15.5°)	1200	Measure	Measure	Adjust. point
Idle	-	-	-	Check point
Full speed	-	-	-	Check point

(In-put voltage: 10V)

* A control lever position of approx. 15.5°, means that a block gauge of 8.4 mm thickness is inserted between the control lever and the idling stopper bolt.

$$V \pm 0.05 = 0.1115 Q + 2.7557 (V)$$

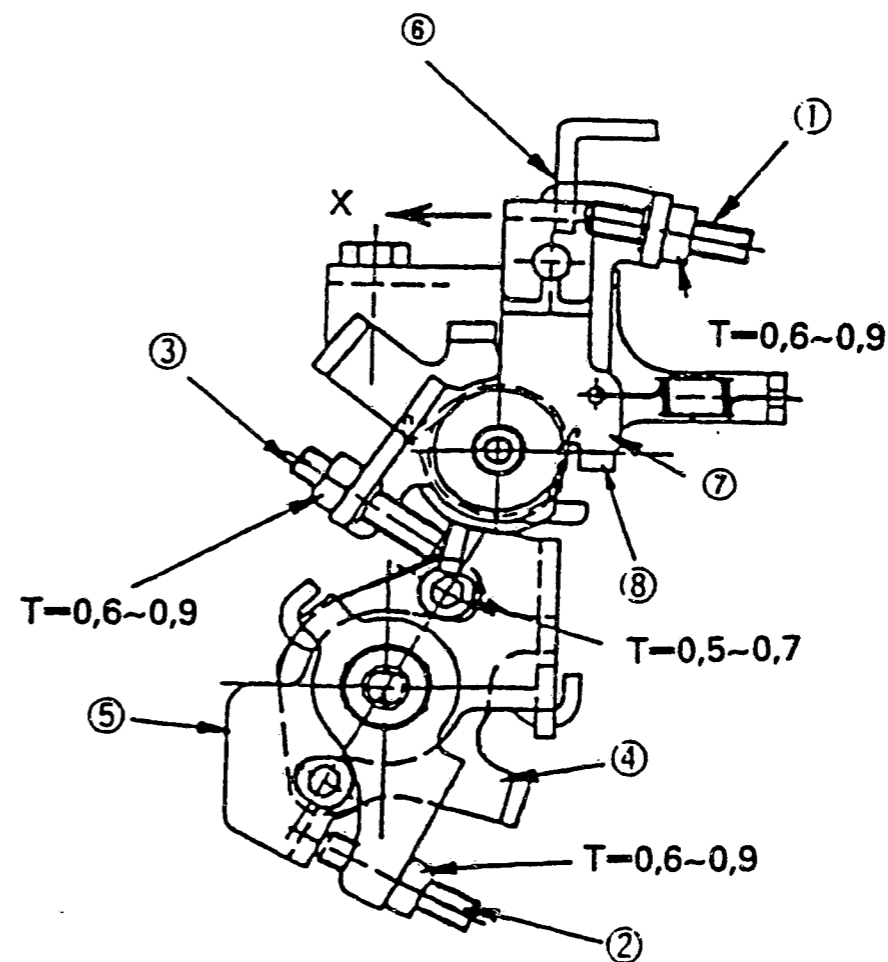
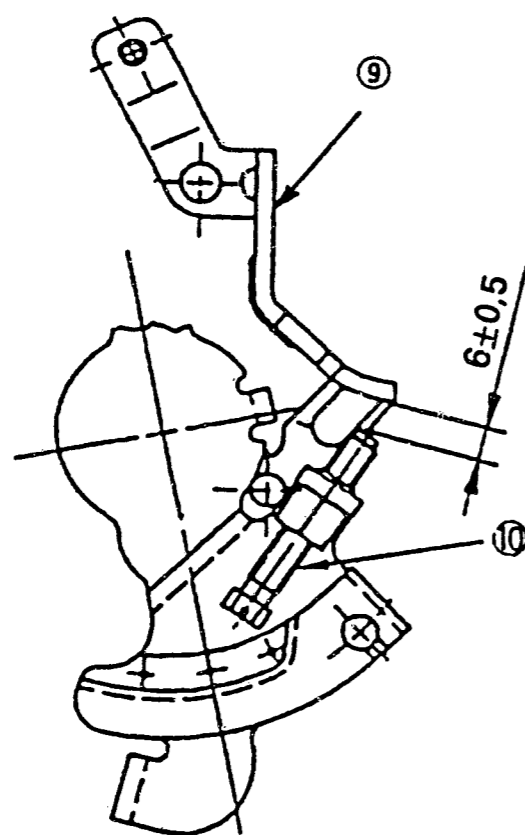

Fig. 31

104769-2162 3/4

9 = Idling set bracket

6 = Control lever
7 = Intermediate lever

M-CSD ADJUSTMENT

1. CSD Adjustment

- 1) Hold the control lever (6) in the idling position.
- 2) Move the CSD lever (5) to the right until it contacts the stopper (4).
- 3) Then, adjust the position of the screw (2) so that the timer stroke is 1.6 ± 0.2 mm and fix the screw (2) using the nut.

E7

ZEXEL - Test values
Injection pumps



E8

ZEXEL - Test values
Injection pumps



(Continued)

2. Fixing the Intermediate Lever Adjustment Screw

- 1) Hold the CSD lever (5) in the position described in item 1 (timer stroke: 1.6 ± 0.2 mm).
- 2) Move the intermediate lever (7) toward "X" and confirm that it contacts the stopper (8).
- 3) Then, adjust the screw (3) so that the CSD lever (5) contacts the screw (3) and fix the screw (3) using the nut.
- 4) Return the intermediate lever (7) to its original position and confirm that the timer stroke is 0 mm.

3. Screw (1) Adjustment

- 1) Move the intermediate lever (7) toward "X" until it contacts the stopper (8).
- 2) Adjust the position of the screw (1) so that the gap between the idling set bracket (9) and screw (10) is 6 ± 0.5 mm, and fix screw (1) using the nut.
- 3) Then, confirm that the gap between the control lever (6) and screw (1) is approximately 1.7 mm.

E9

ZEXEL - Test values

Injection pumps



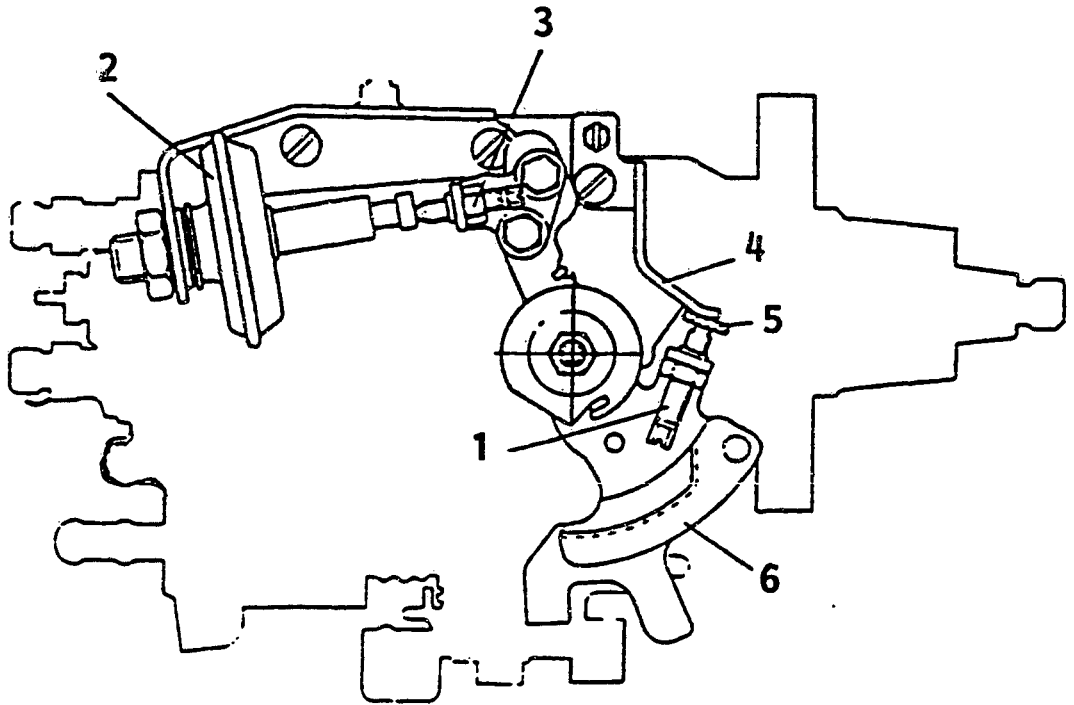

Figure 32

104769-2162 4/4

- 1 = Idling stopper bolt
- 2 = Dash pot
- 3 = Dash pot adjusting screw

- 4 = Bracket
- 5 = Block gauge
- 6 = Control lever

■ DASH POT ADJUSTMENT

1. Insert a block gauge (thickness gauge) of thickness 3.8 ± 0.05 mm in the gap between the idling stopper bolt and the bracket.
2. With the control lever positioned as described in 1. above, adjust the dashpot adjusting screw so that the dashpot adjusting screw and the pushrod are in contact. Fix the screw using the nut.



Test oil:
ISO 4113 or
SAE J967d

ZEXEL - TEST VALUES
Distributors pumps
Engine model: RD28

1/3

BOSCH No. 9 460 610 454
ZEXEL No. 104769-2174
Date: 30.05.1991 [0]
Company: NISSAN
No. 16700 C9601

Injection pump no: 104669-2174 (NP-VE6/9F2500RNP59)

Pump rotation: Clockwise-viewed from drive side
Test-nozzle holder combination: 1 688 901 000
Test pressure line: 1 680 750 017

1. Setting values	Speed (rpm)	Setting values	Charge-air pressure bar (mmHg)	Difference (cc)
1-1 Timing device travel	1200	2.0 - 2.4 (mm)		
1-2 Supply pump pressure	1200	4.2 - 4.8 (kg/cm ²)		
1-3 Full load delivery	900	29.0 - 30.0 (cc/1000st)		2.5
Full load delivery		(cc/1000st)		
1-4 Idle speed regulation	350	5.8 - 8.8 (cc/1000st)		1.4
1-5 Start	100	above 38.0 (cc/1000st)		20.0
1-6 Full-load speed regulation	2600	15.5 - 21.5 (cc/1000st)		5.0
1-7 Load-timer adjustment				

2. Test values

2-1 Timing device	N = rpm mm	900 1.9 - 2.5	1800 4.9 - 5.7	2500 7.3 - 8.2
2-2 Supply pump	N = rpm kg/cm ²	1200 4.1 - 4.9	1800 5.5 - 6.3	2500 7.2 - 8.0
2-3 Overflow delivery	N = rpm cc/10s	1200 48.0 - 92.0		

2-4 Fuel injection quantities

Control lever position	Speed rpm	Fuel delivery (cc/1000 strokes)	Charge-air pres (mmHg)	Difference (cc)
End stop	900	28.5 - 30.5		
	600	27.1 - 31.1		
	2300	26.8 - 30.8		
	2600	15.0 - 22.0		
	2800	below 5.0		
Switch off	350	0		
	900	0		
Idle stop	350	5.3 - 9.3		
	500	below 4.0		

2-5 Solenoid
Cut-in voltage max. 8 V
Test voltage: 12 - 14 V

3. Dimensions

K	3.2 - 3.4 mm
KF	6.54 - 6.74 mm
MS	1.7 - 1.9 mm
BCS	- mm
Pre-st.	- mm

Control lever angle

α	19° - 27° deg
A	8.7 - 12.9 mm
β	37° - 47° deg
B	11.5 - 15.2 mm
γ	10.5 - 11.5 deg
C	5.7 - 6.3 mm

E11

ZEXEL - Test values
Injection pumps



E12

ZEXEL - Test values
Injection pumps



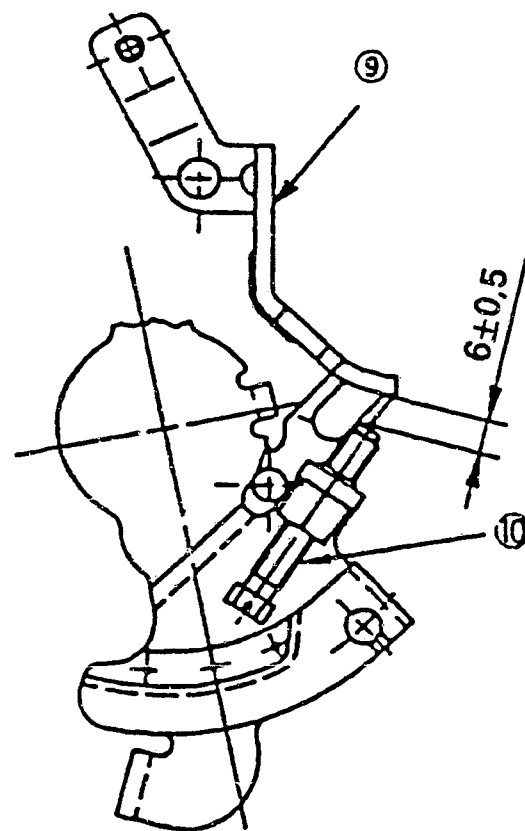

9 = Idling set bracket

■ M-CSD ADJUSTMENT

1. CSD Adjustment

- 1) Hold the control lever (6) in the idling position.
- 2) Move the CSD lever (5) to the right until it contacts the stopper (4).
- 3) Then, adjust the position of the screw (2) so that the timer stroke is 1.6 ± 0.2 mm and fix the screw (2) using the nut.

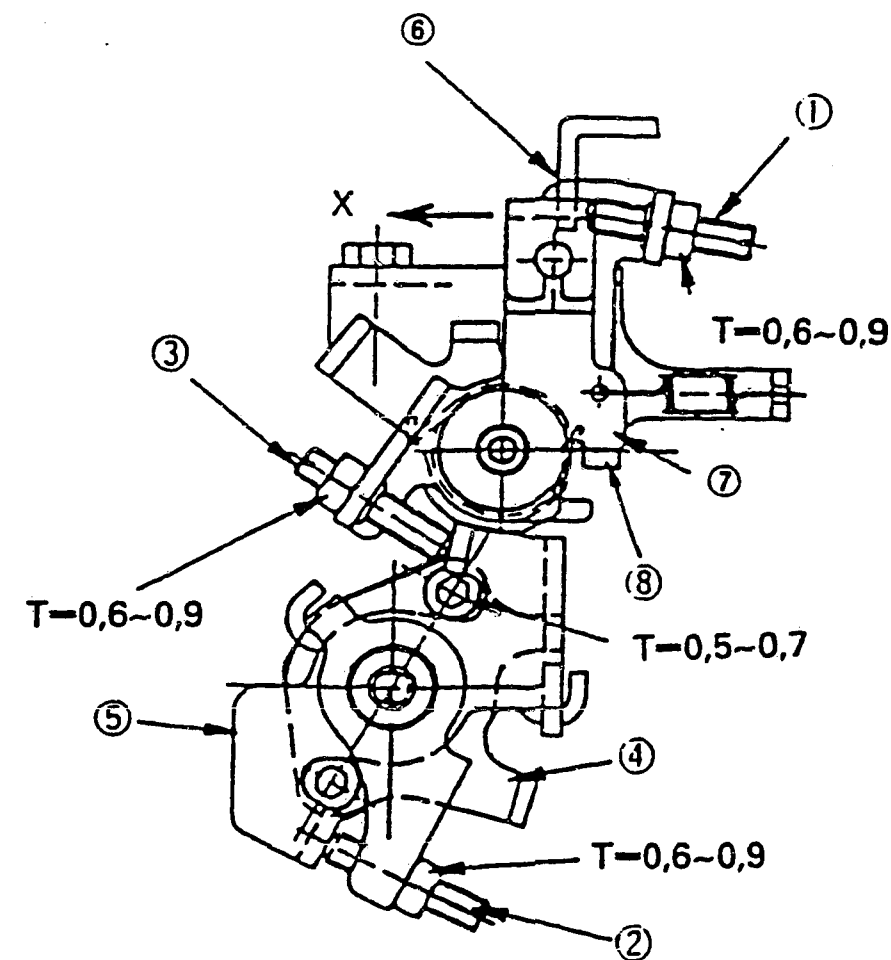

Fig. 33

6 = Control lever
7 = Intermediate lever



(Continued)

2. Fixing the Intermediate Lever Adjustment Screw

- 1) Hold the CSD lever (5) in the position described in item 1 (timer stroke: 1.6 ± 0.2 mm).
- 2) Move the intermediate lever (7) toward "X" and confirm that it contacts the stopper (8).
- 3) Then, adjust the screw (3) so that the CSD lever (5) contacts the screw (3) and fix the screw (3) using the nut.
- 4) Return the intermediate lever (7) to its original position and confirm that the timer stroke is 0 mm.

3. Screw (1) Adjustment

- 1) Move the intermediate lever (7) toward "X" until it contacts the stopper (8).
- 2) Adjust the position of the screw (1) so that the gap between the idling set bracket (9) and screw (10) is 6 ± 0.5 mm, and fix screw (1) using the nut.
- 3) Then, confirm that the gap between the control lever (6) and screw (1) is approximately 1.7 mm.

E15

ZEXEL - Test values

Injection pumps



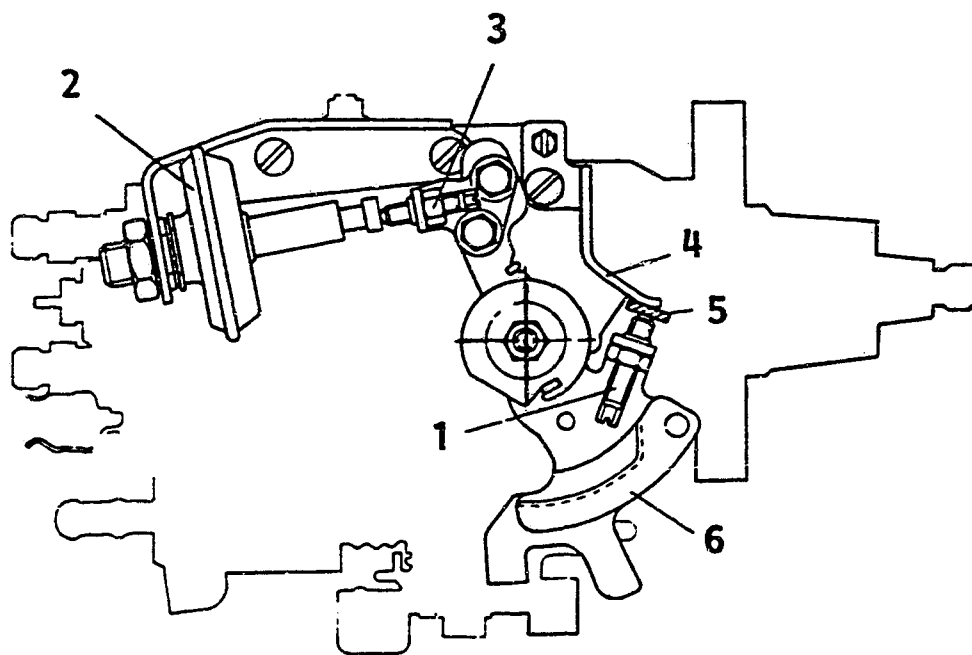

Figure 34

104769-2174 3/3

- 1 = Idling stopper bolt
- 2 = Dash pot
- 3 = Dash pot adjusting screw
- 4 = Bracket
- 5 = Block gauge
- 6 = Control lever

■ DASH POT ADJUSTMENT

1. Insert a block gauge (thickness gauge) of thickness 2.7 ± 0.05 mm in the gap between the idling stopper bolt and the bracket.



(Continued)

2. With the control lever positioned as described in 1. above, adjust the dashpot adjusting screw so that the dashpot adjusting screw and the pushrod are in contact.
Fix the screw using the nut.

Caution:

- The adjusting screw and the pushrod must move together smoothly.
- Confirm that the control lever returns to the idling position.

E17

ZEXEL - Test values

Injection pumps



Test oil
ISO 4113 or
SAE J967d

ZEXEL - TEST VALUES
Distributor pumps
Engine model: RD28-T

BOSCH No. 9 460 610 487
ZEXEL No. 104769-2180
Date: 30.05.1991 [0]
Company: NISSAN
No. 16700 22J01

Injection pump no.: 104669-2152 (NP-VE6/9F2300RNP57)

Pump rot.: Clockwise-viewed from drive side Test-nozzle holder combination: 1 688 901 022 Test pressure line: 1 680 750 073

1. Setting values		Speed (rpm)	Setting values	Charge-air pressure bar (mmHg)	Difference (cc)
1-1	Timing device travel	900	1.1 - 1.5 (mm)	342 - 362	
1-2	Supply pump pressure	900	3.5 - 4.1 (kg/cm ²)	342 - 362	
1-3	Full load delivery	600 (Full)	31.3 - 32.1 (cc/1000st)	0	2.0
	Full load delivery	900 (BCS)	38.6 - 39.4 (cc/1000st)	240 - 260	2.0
1-4	Idle speed regulation	350	6.6 - 8.6 (cc/1000st)	0	0.9
1-5	Start	100	above 38.0 (cc/1000st)	0	
1-6	Full-load speed regulation	2350	34.8 - 36.8 (cc/1000st)	470 - 490	4.5
1-7	Load-timer adjustment				

2. Test values

2-1 Timing device	N = rpm	900	1800	2300	2500
	mm	1.0-1.6	4.1-5.7	6.1-7.4	6.4-7.4
2-2 Supply pump	N = rpm	900	1800	2300	
	kg/cm ²	3.5-4.1	5.6-6.2	6.9-7.5	
2-3 Overflow delivery	N = rpm	900			
	cc/10s	43.0-87.0			

2-4 Fuel injection quantities

Speed control lever pos.	Speed (rpm)	Fuel delivery (cc/1000st)	Charge-air pres (mmHg)	Difference (cc)
End stop	600 (Full)	30.7 - 32.7	0	
	900 (BCS)	38.0 - 40.0	240 - 260	
	1200	41.9 - 45.9	470 - 490	
	1800	40.8 - 44.8	470 - 490	
	2200	39.5 - 45.5	470 - 490	
	2300	34.3 - 37.3	470 - 490	
	2400	22.4 - 32.4	470 - 490	
Switch off	900 (Full)	0	342 - 362	
	350 (Idle)	0	-	
Idle-stop	500	below 3.0	0	
	350	6.6 - 8.6	0	

2-5 Solenoid Cut-in voltage max. 8 V Test voltage: 12 - 14 V

3. Dimensions

K	3.2 - 3.4 mm
KF	6.54 - 6.74 mm
MS	1.7 - 1.9 mm
BCS	3.8 - 4.0 mm
Pre-st.	- mm
Control lever angle	
α	19 - 27° deg
A	8.7 - 12.6 mm
β	34 - 44° deg
B	10.5 - 14.2 mm
γ	15 - 16° deg
C	7.9 - 9.5 mm

E18

ZEXEL - Test values
Injection pumps



E19

ZEXEL - Test values
Injection pumps



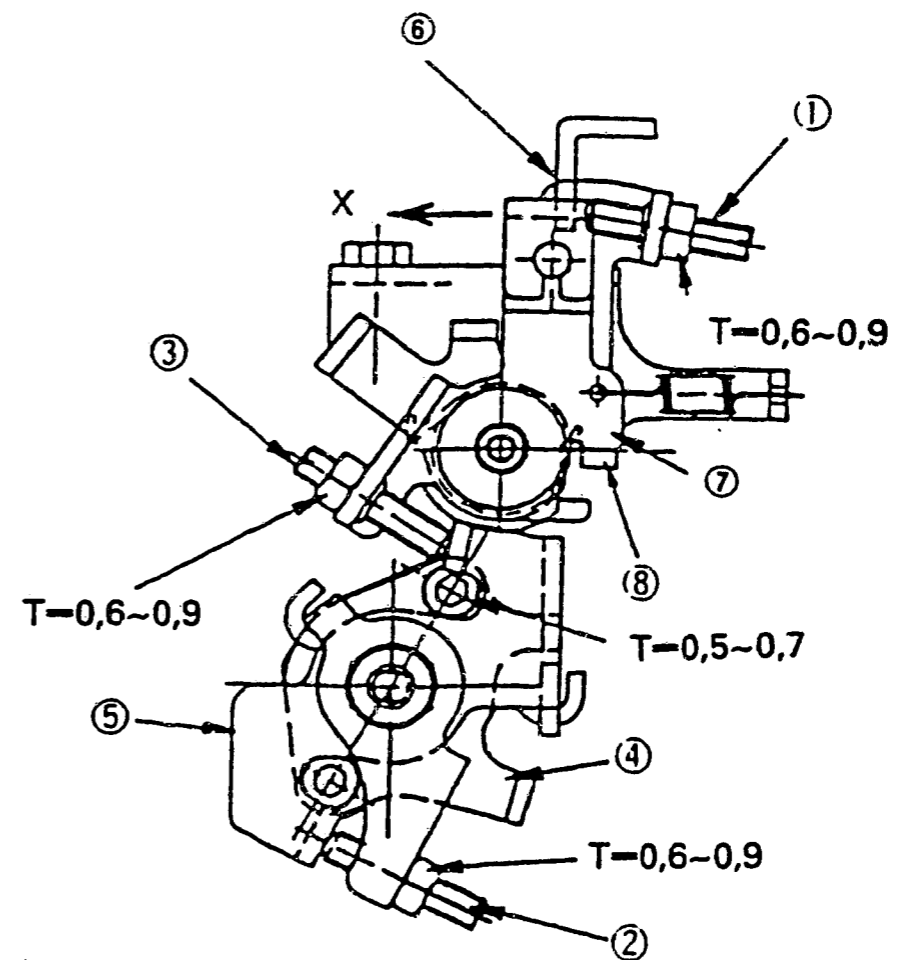
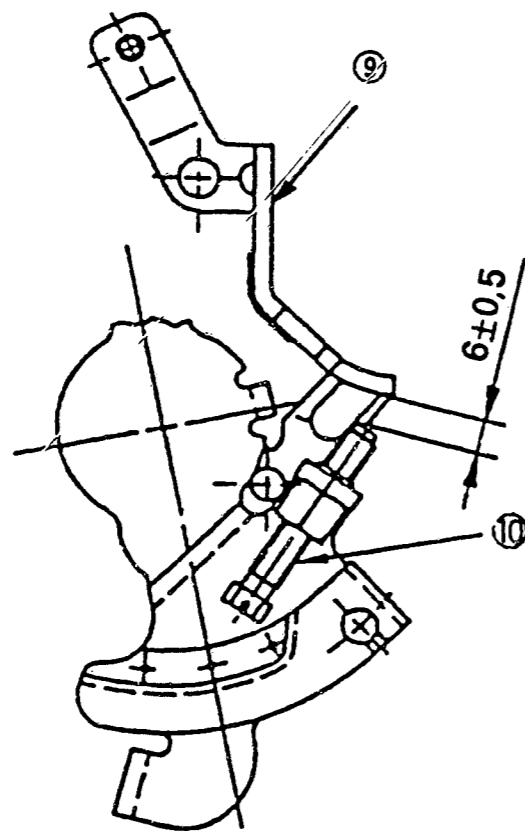

Fig. 35

9 = Idling set bracket

6 = Control lever
7 = Intermediate lever

■ M-CSD ADJUSTMENT

1. CSD Adjustment

- 1) Hold the control lever (6) in the idling position.
- 2) Move the CSD lever (5) to the right until it contacts the stopper (4).
- 3) Then, adjust the position of the screw (2) so that the timer stroke is 1.6 ± 0.2 mm and fix the screw (2) using the nut.



(Continued)

2. Fixing the Intermediate Lever Adjustment Screw

- 1) Hold the CSD lever (5) in the position described in item 1 (timer stroke: 1.6 ± 0.2 mm).
- 2) Move the intermediate lever (7) toward "X" and confirm that it contacts the stopper (8).
- 3) Then, adjust the screw (3) so that the CSD lever (5) contacts the screw (3) and fix the screw (3) using the nut.
- 4) Return the intermediate lever (7) to its original position and confirm that the timer stroke is 0 mm.

3. Screw (1) Adjustment

- 1) Move the intermediate lever (7) toward "X" until it contacts the stopper (8).
- 2) Adjust the position of the screw (1) so that the gap between the idling set bracket (9) and screw (10) is 6 ± 0.5 mm, and fix screw (1) using the nut.
- 3) Then, confirm that the gap between the control lever (6) and screw (1) is approximately 1.7 mm.

E22

ZEXEL - Test values

Injection pumps



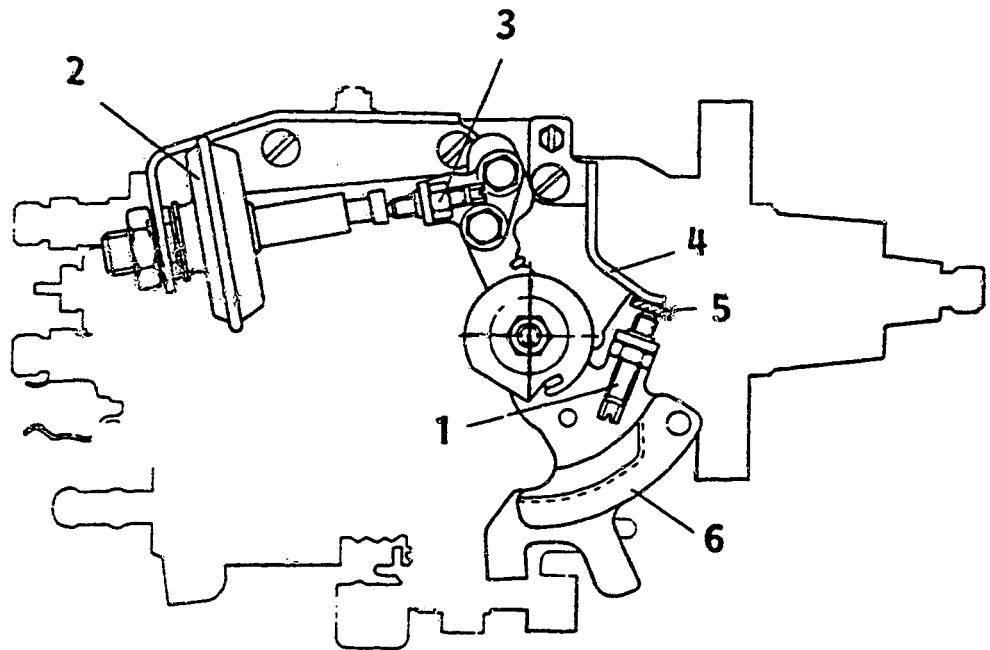

Figure 36

104769-2180 3/3

- 1 = Idling stopper bolt
- 2 = Dash pot
- 3 = Dash pot adjusting screw

- 4 = Bracket
- 5 = Block gauge
- 6 = Control lever

■ DASH POT ADJUSTMENT

1. Insert a block gauge (thickness gauge) of thickness 3.8 ± 0.05 mm in the gap between the idling stopper bolt and the bracket.
2. With the control lever positioned as described in 1. above, adjust the dashpot adjusting screw so that the dashpot adjusting screw and the pushrod are in contact. Fix the screw using the nut.

